

Pablo®

SKY

PENDANT SERIES

120/240V ASSEMBLY & INSTALLATION INSTRUCTIONS

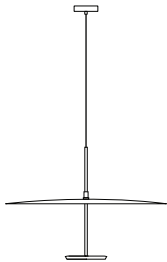

DOME



SOLO

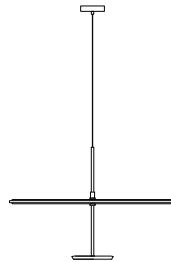

SOUND

INFO@PABLODESIGNS.COM
888 MARIN STREET
SAN FRANCISCO, CA
94124

PABLODESIGNS.COM



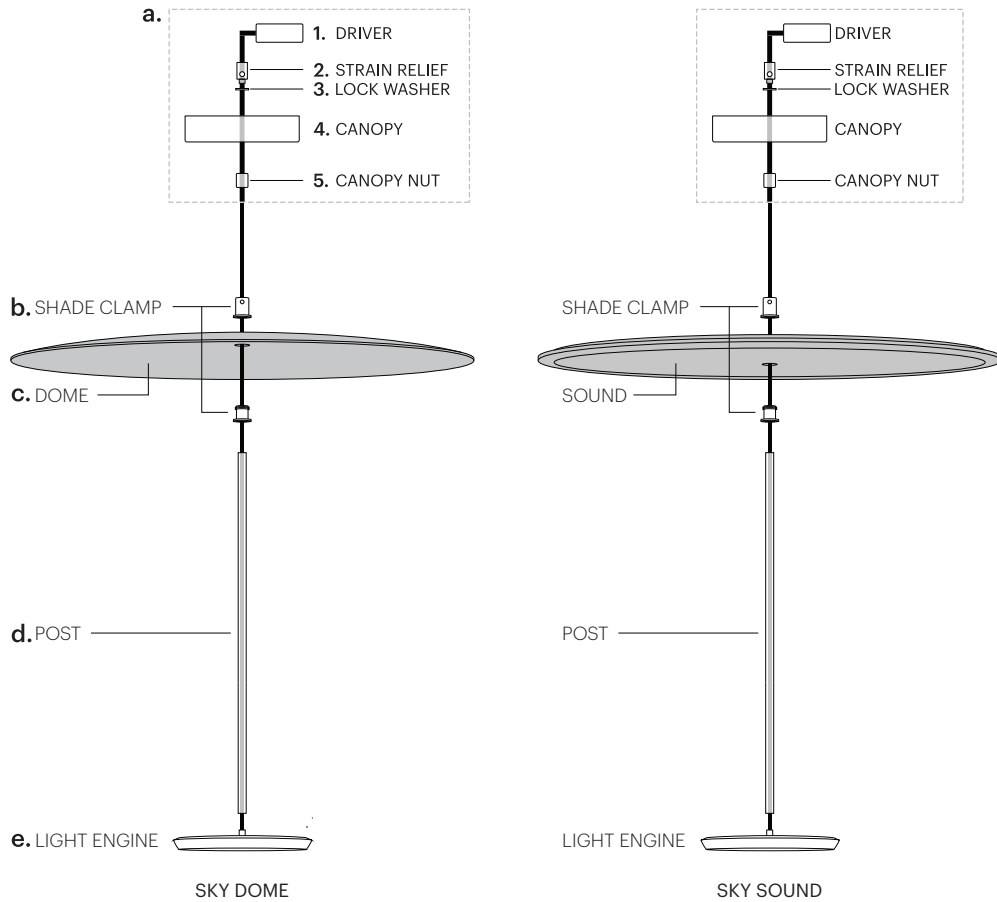

1. **a** SECURE DRIVER TO BRACKET WITH PROVIDED TAPE. **b** SECURE BRACKET TO JUNCTION BOX OR CEILING.

2. **a** WEAVE CORD THROUGH POST (**ENTER THREADED SIDE**) **b** THREAD POST ONTO LIGHT ENGINE.

ATTENTION! SKIP TO STEP 5 FOR SKY SOLO

3. SECURE SHADE CLAMP TO SHADE (SEE DETAIL VIEW FOR PROPER ASSEMBLY).

4. SLIDE SHADE ASSEMBLY ONTO POST AND SECURE WITH PROVIDED ALLEN KEY. REFERENCE SHADE HEIGHT OFFSET TABLE FOR RECOMMENDED SHADE PLACEMENT. (**ATTENTION! BE SURE SET SCREW DOES NOT**

OBSTRUCT POST PATH THROUGH CLAMP ASSEMBLY)

IMPORTANT! BE SURE TO REFERENCE CORD PATH DIAGRAM BEFORE MOVING ON.

5. BE SURE TO WEAVE CORD THROUGH ALL NECESSARY PARTS LISTED ABOVE BASED ON LAMP MODEL.

a BEND WIRE ENDS BEFORE PASSING THROUGH STRAIN RELIEF. **b** PASS CORD THROUGH STRAIN RELIEF AND SET LAMP HEIGHT BY FASTENING BOTH (TOP AND SIDE) SET SCREWS. (IF NECESSARY : TRIM EXCESS CORD)

6. PLACE FASTENED STRAIN RELIEF ONTO MOUNTING BRACKET WITH LOCK WASHER PLACED BETWEEN

BRACKET AND STRAIN RELIEF. (**ATTENTION! STRAIN RELIEF NESTS INTO RECESS IN BRACKET**)

7. WIRE DRIVER TO BUILDING (US : BLACK TO BLACK/WHITE TO WHITE) (EU : BLACK TO BROWN/WHITE TO BLUE)

NOTE: PURPLE AND GREY WIRES ARE USED ONLY IN 0-10V INSTALLATIONS.

8. WIRE DRIVER TO LAMP (RED TO RED/BLUE TO BLACK)

9. SECURE CANOPY COVER TO BRACKET ASSEMBLY WITH CANOPY NUT. TIGHTEN UNTIL FIRMLY IN PLACE.

DE: DRAHTPFADDIAGRAMM

- a. 1. TRANSFORMATOR
- 2. DRAHTKLEMME
- 3. SICHERUNGSSCHEIBE
- 4. ÜBERDACHUNG
- 5. ÜBERDACHUNG BOLZEN
- b. SCHATTENKLEMME
- c. SCHATTEN
- d. DER STAB
- e. LICHTMOTOR

1. **a**. SICHEREN SIE DEN FAHRER MIT DEM MITGELIEFERTEN BAND AN DER HALTERUNG. **b**. SICHERE HALTERUNG AN VERZWEIGUNGSKASTEN ODER DECKEN.

2. **a**. DRUCKKABEL DURCH POST (GEWINDESEITE EINGEBEN) **b**. GEWINDEPOST AUF LICHTMOTOR.

BEACHTUNG! WEITER ZU SCHRITT 5 FÜR SKY SOLO

3. SICHERN SIE DIE SCHATTENKLAMMER FÜR DEN SCHATTEN (SIEHE DETAILANSICHT FÜR DIE RICHTIGE MONTAGE).

FR: DIAGRAMME DU CHEMIN DE FIL

- a. 1. TRANSFORMATEUR
- 2. PINCE À FIL
- 3. RONDELLE DE VERROUILLAGE
- 4. CANOPÉE
- 5. CANOPÉE BOULON
- b. PINCE D'OMBRE
- c. OMBRE
- d. PÔLE
- e. MOTEUR LÉGER

1. **a**. FIXEZ LE CONDUCTEUR AU SUPPORT AVEC LE RUBAN FOURNI. **b**. FIXER LE SUPPORT À LA BOÎTE DE JONCTION OU AU PLAFOND.

2. **a**. POUSSER LE CORDON À TRAVERS LA TIGE (ENTREZ SUR LE CÔTÉ FILETÉ) **b**. FILETER LA TIGE SUR LE MOTEUR ÉCLAIR.

ATTENTION! PASSEZ À L'ÉTAPE 5 POUR SKY SOLO

3. FIXEZ LA PINCE D'OBJECTIF À L'OBJET (VOIR LA VUE DE DÉTAIL POUR UN ASSEMBLAGE APPROPRIÉ).

ES: DIAGRAMA DE RUTA DE ALAMBRE

- a. 1. TRANSFORMADOR
- 2. ABRAZADERA DE ALAMBRE
- 3. ARANDELA DE BLOQUEO
- 4. PABELLÓN
- 5. PABELLÓN TORNILLO
- b. ABRAZADERA DE SOMBRA
- c. SOMBRA
- d. POSTE
- e. MOTOR LIGERO

1. **a**. ASEGURAR EL CONDUCTOR AL SOPORTE CON LA CINTA PROPORCIONADA. **b**. SUJECCIÓN DEL SOPORTE A LA CAJA DE CONEXIONES O AL TECHO.

2. **a**. EMPUJE EL CABLE A TRAVÉS DEL POSTE (ENTRE EL LADO ROSCADO) **b**. ENROSQUE EL POSTE EN EL MOTOR DE LA LUZ.

¡ATENCIÓN! SALTE AL PASO 5 PARA SKY SOLO

3. SUJECCIÓN DE LA ABRAZADERA DE LA CORTINA A LA CORTINA (VER VISTA DETALLADA PARA UN MONTAJE CORRECTO).

IT: SCHEMA DEL PERCORSO DEL FILO

- a. 1. TRASFORMATORE
- 2. MORSETTO PER FILO
- 3. RONDELLA DI BLOCCO
- 4. BALDACCHINO
- 5. BALDACCHINO BULLONE
- b. MORSETTO OMBRA
- c. OMBRA
- d. PALO
- e. MOTORE LEGGERO

1. **a**. FISSARE IL DRIVER SU STAFFA CON NASTRO IN DOTAZIONE. **b**. FISSARE LA STAFFA ALLA SCATOLA DI GIUNZIONE O AL SOFFITTO.

2. **a**. SPINGERE IL CAVO ATTRAVERSO IL PALO (ENTRARE NEL LATO FILETTATO) **b**. FILETTARE IL PALO SUL MOTORE LEGGERO.

ATTENZIONE! SALTA AL PASSO 5 PER SKY SOLO

3. FISSARE IL MORSETTO DELL'OMBRA SULL'OMBRA (VEDERE LA VISTA IN DETTAGLIO PER IL MONTAGGIO CORRETTO).

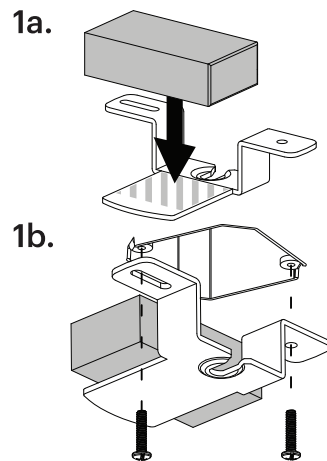
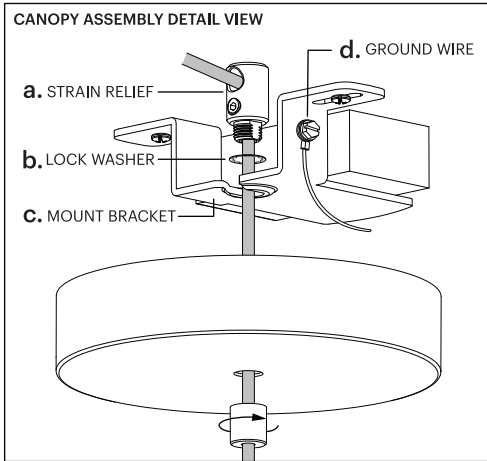

DE: DETAILANSICHT DER BALDACHINBAUGRUPPE

- a. DRAHTKLEMME
- b. SICHERUNGSSCHEIBE
- c. KLAMMER
- d. ERDUNGSKABEL

4. BEWEGEN SIE DIE SCHATTENMONTAGE AUF DEN POST UND SICHERN SIE MIT DEM BEREITGESTELLTEN ALLEN-SCHLÜSSEL. REFERENZSCHATTENHÖHE-OFFSET-TABELLE FÜR EMPFOHLENE SCHATTENPLATZIERUNG. (ACHTUNG! SICHERSTELLEN, DASS DIE SCHRAUBE DEN POST-WEG NICHT DURCH DIE MONTAGE DER KLEMME BEHINDERT)

WICHTIG! VERWEISEN SIE UNBEDINGT AUF DAS KABELPFADDIAGRAMM, BEVOR SIE FORTFAHREN.

5. VERGEWISSERN SIE SICH, DASS SIE DAS KABEL DURCH ALLE OBEN AUFGEFÜHRTEN ERFORDERLICHEN TEILE AUF DER GRUNDLAGE DES LAMPENMODELLS GEWEBT HABEN. **a.** BIEGEDRAHT ENDET, BEVOR ER DURCH DIE ENTLASTUNG GEHT. **b.** FÜHREN SIE DAS KABEL DURCH DIE ZUGENTLASTUNG UND STELLEN SIE DIE LAMPENHÖHE EIN, INDEM SIE BEIDE (OBEN UND SEITLICH) EINGESTELLTEN SCHRAUBEN BEFESTIGEN. (WENN ERFORDERLICH: TRIM EXCESS CORD)

FR: VUE DÉTAILLÉE DE L'ASSEMBLAGE DE LA VERRIÈRE

- a. PINCE À FIL
- b. RONDELLE DE VERROUILLAGE
- c. SUPPORT DE MONTAGE
- d. FIL DE TERRE

4. DÉPLACER L'ENSEMBLE DU PARE-CHOCS SUR LE MONTANT ET FIXER AVEC LA CLÉ ALLEN FOURNIE. TABLEAU DE DÉCALAGE DE LA HAUTEUR DE L'OMBRE DE RÉFÉRENCE POUR LE PLACEMENT RECOMMANDÉ DE L'OMBRE. (ATTENTION! S'ASSURER QUE LA VIS DE RÉGLAGE N'OBSTRUE PAS LE CHEMIN DE LA POSTE À TRAVERS L'ASSEMBLAGE DE LA PINCE)

IMPORTANT! ASSUREZ-VOUS DE CONSULTER LE DIAGRAMME DE CHEMINEMENT DU CORDON AVANT DE MISE EN ROUTE.

5. ASSUREZ-VOUS DE FAIRE FIXER LE CORDON À TRAVERS TOUTES LES PIÈCES NÉCESSAIRES ÉNUMÉRÉES CI-DESSUS EN FONCTION DU MODÈLE DE LA LAMPE. **a.** FIL DE COURBE SE TERMINE AVANT DE PASSER À TRAVERS LE DÉTENTE DE DÉTENTE **b.** PASSER LE CORDON À TRAVERS LE RELIEF DE DÉTENTE ET RÉGLER LA HAUTEUR DE LA LAMPE EN FIXANT LES DEUX VIS DE RÉGLAGE (SUPÉRIEUR ET CÔTÉ). (SI NÉCESSAIRE: TRIM EXCESS CORD)

ES: VISTA DETALLADA DEL MONTAJE DE LA MARQUESINA

- a. ABRAZADERA DE ALAMBRE
- b. ARANDELA DE BLOQUEO
- c. SOPORTE DE MONTAJE
- d. ALAMBRE DE TIERRA

4. MUEVA EL CONJUNTO DE LA CORTINA SOBRE EL POSTE Y SUJETE CON LA LLAVE ALLEN PROPORCIONADA. TABLA DE DESPLAZAMIENTO DE ALTURA DE TONOS DE REFERENCIA PARA LA COLOCACIÓN RECOMENDADA DE TONOS. (¡ATENCIÓN! ASEGÚRESE DE QUE EL TORNILLO DE FIJACIÓN NO OBSTRUYA LA RUTA DEL POSTE A TRAVÉS DEL CONJUNTO DE LA ABRAZADERA)

¡IMPORTANTE! ASEGÚRESE DE HACER REFERENCIA AL DIAGRAMA DE LA RUTA DEL CABLE ANTES DE SEGUIR.

5. ASEGÚRESE DE TEJER EL CORDÓN A TRAVÉS DE TODAS LAS PIEZAS NECESARIAS MENCIONADAS ARRIBA SEGÚN EL MODELO DE LÁMPARA. **a.** DOBLE LOS EXTREMOS DEL ALAMBRE ANTES DE PASAR POR EL ALIVIO DE TENSION. **b.** PASAR EL CABLE A TRAVÉS DEL ALIVIO DE TENSION Y AJUSTAR LA ALTURA DE LA LÁMPARA FIJANDO AMBOS TORNILLOS DE FIJACIÓN (SUPERIOR Y LATERAL). (SI ES NECESARIO: CORTE EL EXCESO DEL CABLE)

IT: VISTA DI DETAGLIO DELL'ASSIEME DEL BALDACCHINO

- a. MORSETTO PER FILO
- b. RONDELLA DI BLOCCO
- c. STAFFA DI MONTAGGIO
- d. FILO DI TERRA

4. SPOSTARE IL GRUPPO OMBREGGIANTE SUL POST E FISSARLO CON LA CHIAVE A BRUGOLA FORNITA. TABELLA DI RIFERIMENTO ALTEZZA OMBRA DI RIFERIMENTO PER IL POSIZIONAMENTO DELL'OMBRA CONSIGLIATO. (ATTENZIONE! ASSICURARSI CHE LA VITE DI FISSAGGIO NON OSTACCHI IL PERCORSO DEL POST ATTRAVERSO IL GRUPPO MORSETTO)

IMPORTANTE! ASSICURARSI DI FARE RIFERIMENTO DELLO SCHEMA DEL PERCORSO DEL CAVO PRIMA DI MUOVERSI.

5. ASSICURARSI DI TESSERE IL CAVO ATTRAVERSO TUTTE LE PARTI NECESSARIE SOPRA ELENcate IN BASE AL MODELLO DI LAMPADA. **a.** PIEGARE IL FILO FINISCE PRIMA DI PASSARE ATTRAVERSO IL DISPOSITIVO DI SICUREZZA. **b.** FARE PASSARE IL CAVO ATTRAVERSO IL FERMACAVO E REGOLARE L'ALTEZZA DELLA LAMPADA FISSANDO ENTRAMBE LE VITI DI FISSAGGIO (SUPERIORE E LATERALE). (SE NECESSARIO: TRIM EXCESS CORD)

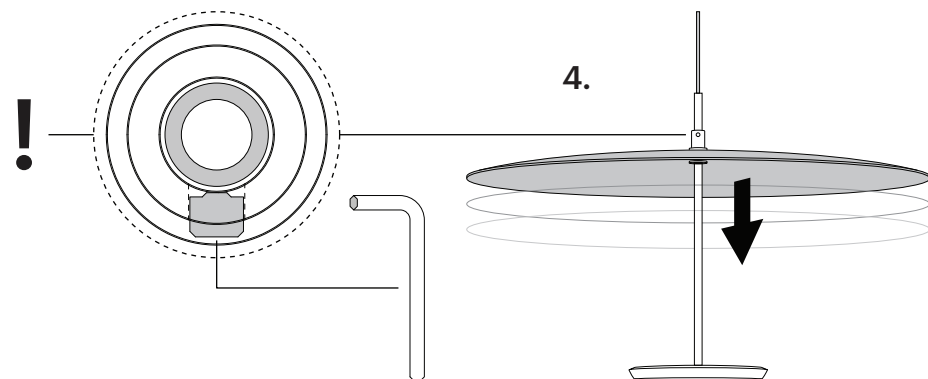
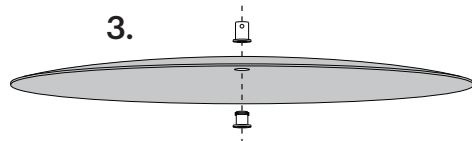
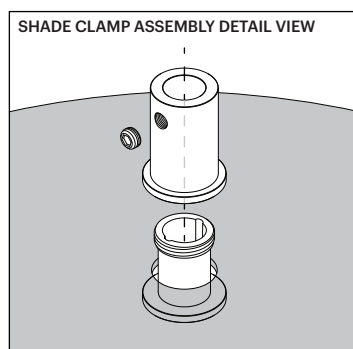
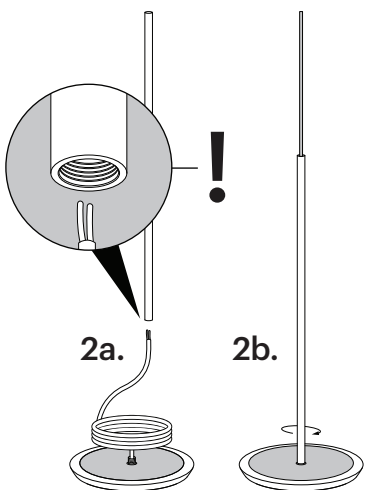

5a.

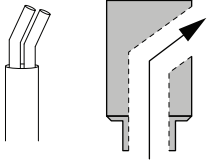

5b.

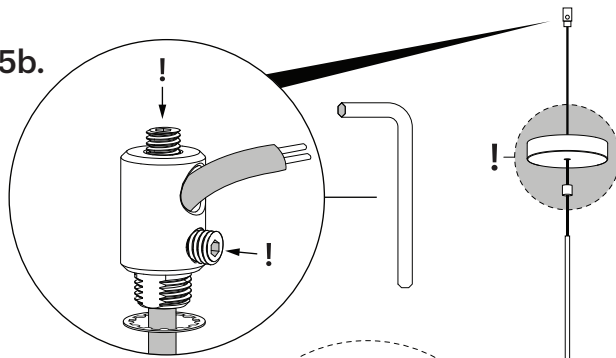

6.

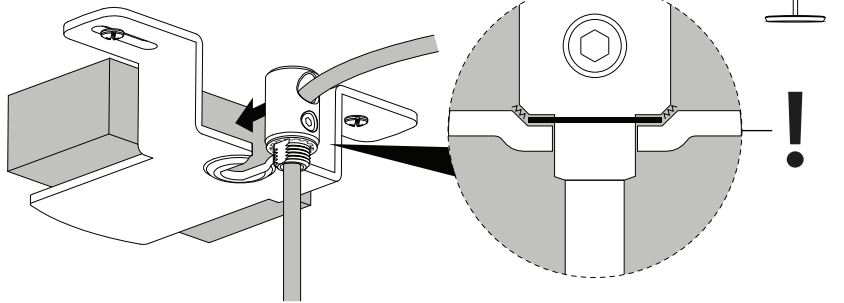

7-8.

WIRING DIAGRAM

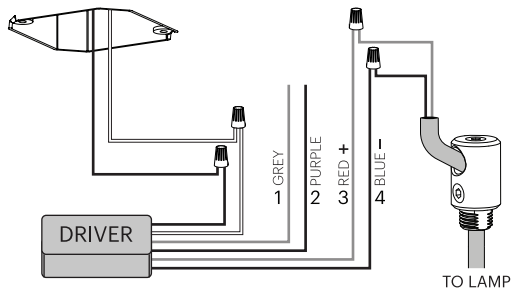

BULB TYPE

LED
FULL-RANGE LIGHT CONTROL VIA
0 - 10V OR ELV DIMMER

BULB REPLACEMENT

CONTACT MANUFACTURER FOR BULB
REPLACEMENT

LENGTH OF CORD SUPPLIED

10FT (304CM)

CARE

WIPE WITH A CLEAN, DAMP CLOTH,
AVOID AMMONIA-BASED CLEANERS.
POLISHING CLOTH INCLUDED

**IMPORTANT: WE RECOMMEND
CEILING MOUNTING BE INSTALLED
BY AN ELECTRICIAN**

SHADE HEIGHT

SKY DOME

18 : 9.5"(24.13cm)

24 : 8.5"(21.6cm)

32 : 7.5"(19cm)

SKY SOUND

18 : 9.5"(24.13cm)

24 : 8.5"(21.6cm)

32 : 7.5"(19cm)

9.

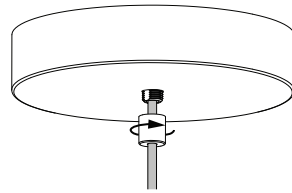

SKY PENDANT ASSEMBLY

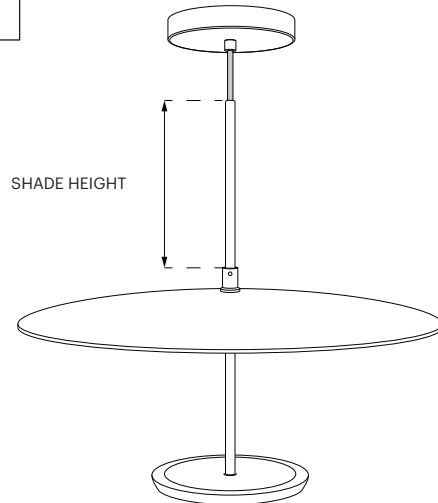

DE:

6. BEFESTIGTE STRAIN-ENTLASTUNG AUF DIE MONTAGEHALTERUNG MIT ZWISCHEN HALTERUNG UND STRAIN-ENTLASTUNG AUF DIE MONTAGEHALTERUNG STELLEN. (ACHTUNG! STRAIN RELIEF NESTS IN NACHRICHT IN HALTERUNG)

7. DRAHTFAHRER ZUM GEBÄUDE (USA: SCHWARZ ZU SCHWARZ / WEISS ZU WEISS) (EU: SCHWARZ ZU BRAUN / WEISS ZU BLAU) HINWEIS: LILA UND GRAUE KABEL WERDEN NUR IN INSTALLATIONEN VON 0-10 V VERWENDET.

8. DRAHTTRANSFORMATOR ZUR LAMPE (ROT ZU ROT / BLAU ZU SCHWARZ)

9. SICHERN SIE DIE ABDECKUNG MIT DER ABDECKMUTTER AN DER HALTERUNG. ZIEHEN, BIS FEST.

SCHALTPLAN

1. GRAU
2. LILA
3. ROT
4. BLAU

FR:

6. PLACER LE SUPPORT DE DÉTENTE FIXÉ SUR LE SUPPORT DE MONTAGE AVEC LA RONDELLE DE VERROUIL-LAGE PLACÉE ENTRE LE SUPPORT ET LE SUPPORT DE DÉTENTE. (ATTENTION! LES NESTS DE SOULAGEMENT DE LA TENSION DANS LE RECESSEMENT DU SUPPORT)

7. FIL PILOTE AU BÂTIMENT (ÉTATS-UNIS: NOIR À NOIR / BLANC À BLANC) (UE: NOIR À MARRON / BLANC À BLEU) REMARQUE: LES FILS VIOLET ET GRIS SONT UTILISÉS UNIQUEMENT DANS LES INSTALLATIONS 0-10V.

8. TRANSFORMATEUR FIL À LAMPE (ROUGE À ROUGE / BLEU À NOIR)

9. FIXER LE COUVERCLE DE CANOPY À L'ENSEMBLE DE SUPPORT À L'AIDE DE L'ÉCROU DE CANOPY. SERRER JUSQU'À FERMEMENT EN PLACE.

SCHÉMA DE CÂBLAGE

1. GRIS
2. VIOLET
3. ROUGE
4. BLEU

ES:

6. COLOQUE EL ALIVIO DE TENSIÓN FIJADO EN EL SOPORTE DE MONTAJE CON LA ARANDELA DE SEGURIDAD COLOCADA ENTRE EL SOPORTE Y EL ALIVIO DE TENSION. (¡ATENCIÓN! EL ALIVIO DE ESFUERZO SE NIDERA EN EL RECESO DEL SOPORTE)

7. CONDUCTOR DE CABLE A EDIFICIO (EE. UU.: NEGRO A NEGRO / BLANCO A BLANCO) (UE: NEGRO A MARRÓN / BLANCO A AZUL) NOTA: LOS CABLES PÚRPURA Y GRIS SE UTILIZAN ÚNICAMENTE EN INSTALACIONES DE 0-10 V.

8. TRANSFORMADOR DE CABLE A LÁMPARA (ROJO A ROJO / AZUL A NEGRO)

9. ASEGURE LA CUBIERTA DEL DOSEL AL CONJUNTO DEL SOPORTE CON LA TUERCA DEL TECHO. APIRIETE HASTA QUE ESTÉ FIRMEMENTE EN SU LUGAR.

DIAGRAMA DE CABLEADO

1. GRIS
2. PÚRPURA
3. ROJO
4. AZUL

IT:

6. POSIZIONARE IL SOLLECITORE FISSATO SULLA STAFFA DI MONTAGGIO CON LA RONDELLA DI BLOCCO POSIZIONATA TRA LA STAFFA E IL DISPOSITIVO DI SICUREZZA. (ATTENZIONE! NIDI DI RILIEVO DEL CEPPO NELL'INCAVO DELLA STAFFA)

7. DRIVER DI CAVO ALL'EDIFICIO (USA: DA NERO A NERO / BIANCO A BIANCO) (UE: DA NERO A MARRONE / BIANCO A BLU) NOTA: I FILI VIOLA E GRIGIO VENGONO UTILIZZATI SOLO NELLE INSTALLAZIONI 0-10V.

8. TRASFORMATORE DI FILO A LAMPADA (DA ROSSO A ROSSO / BLU A NERO)

9. FISSARE LA COPERTURA DEL CANOPY AL MONTAGGIO DELLA STAFFA CON IL DADO DEL CANOPY. STRINGERE FINO A SALDAMENTE IN POSIZIONE.

SCHEMA ELETTRICO

1. GRIGIO
2. VIOLA
3. ROSSO
4. BLU

GLÜHBIRNENTYP: LED / VOLLSTÄNDIGE LICHTSTEUERUNG ÜBER 0 - 10 V ODER ELF DIMMER

AUSTAUSCH DER GLÜHBIRNE: KONTAKTIEREN SIE DEN HERSTELLER FÜR DEN AUSTAUSCH DER GLÜHBIRNE

LÄNGE DER MITGELIEFERTEN KABEL: 304 cm (10 Fuß)

PFLEGE: MIT EINEM SAUBEREN, FEUCHTEN TUCH ABWISCHEN, AMMONIENBASIERTE REINIGER VERMEIDEN. POLIERTUCH ENTHALTEN

WICHTIG: WIR EMPFEHLEN, DIE DECKENMONTAGE VON EINEM ELEKTRIKER INSTALLIEREN ZU LASSEN

TYPE D'AMPOULE: CONTRÔLE DE L'ÉCLAIRAGE À LED / PLEINE PORTÉE VIA 0 - 10V OU VARIATEUR ELV

REPLACEMENT DE L'AMPOULE: CONTACTER LE FABRICANT POUR LE REMPLACEMENT DE L'AMPOULE

LONGUEUR DU CORDON FOURNI: 10FT (304CM)

ENTRETIEN: ESSUYER AVEC UN CHIFFON PROPRE ET HUMIDE, ÉVITER LES NETTOYANTS À BASE D'AMMONIAQUE. TISSU DE POLISSAGE INCLUS

IMPORTANT: NOUS RECOMMANDONS QUE LE MONTAGE AU PLAFOND SOIT INSTALLÉ PAR UN ÉLECTRICIEN

TIPO DE BOMBILLA: LED / CONTROL DE LUZ DE RANGO COMPLETO A TRAVÉS DE 0 - 10V O DIMMER ELV

REEMPLAZO DE BOMBILLAS: CONTACTE AL FABRICANTE PARA REEMPLAZO DE BOMBILLAS

LONGITUD DEL CABLE SUMINISTRADO: 10FT (304CM)

CUIDADO: LIMPIE CON UN PAÑO LIMPIO Y HÚMEDO, EVITE LOS LIMPIADORES A BASE DE AMONÍACO. PAÑO DE PULIDO INCLUIDO

IMPORTANTE: RECOMENDAMOS QUE EL MONTAJE EN EL TECHO LO INSTALE UN ELECTRICISTA

TIPO DI LAMPADINA: LED / CONTROLLO DELLA LUCE A TUTTO GAMMA TRAMITE DIMMER 0 - 10V O ELV

SOSTITUZIONE LAMPADINA: CONTATTARE IL PRODUTTORE PER LA SOSTITUZIONE DELLA LAMPADINA

LUNGHEZZA DEL CAVO FORNITO: 10FT (304CM)

CURA: ASCIUGARE CON UN PANNINO PULITO E UMIDO, EVITARE DETERGENTI A BASE DI AMMONIACA. PANNO PER LUCIDARE INCLUSO

IMPORTANTE: SI CONSIGLIA DI INSTALLARE IL MONTAGGIO A SOFFITTO DA UN ELETTRICISTA

SCHATTENHÖHE

SKY DOME	SKY SOUND
18 : 9.5"(24.13)	18 : 9.5"(24.13)
24 : 8.5"(21.6cm)	24 : 8.5"(21.6cm)
32 : 7.5"(19cm)	32 : 7.5"(19cm)

HAUTEUR DE L'OMBRE

SKY DOME	SKY SOUND
18 : 9.5"(24.13)	18 : 9.5"(24.13)
24 : 8.5"(21.6cm)	24 : 8.5"(21.6cm)
32 : 7.5"(19cm)	32 : 7.5"(19cm)

ALTURA DE SOMBRA

SKY DOME	SKY SOUND
18 : 9.5"(24.13)	18 : 9.5"(24.13)
24 : 8.5"(21.6cm)	24 : 8.5"(21.6cm)
32 : 7.5"(19cm)	32 : 7.5"(19cm)

ALTEZZA OMBRA

SKY DOME	SKY SOUND
18 : 9.5"(24.13)	18 : 9.5"(24.13)
24 : 8.5"(21.6cm)	24 : 8.5"(21.6cm)
32 : 7.5"(19cm)	32 : 7.5"(19cm)

Pablo®

INFO@PABLODESIGNS.COM
INFO@PABLODESIGNS.EU

888 MARIN ST
SAN FRANCISCO, CA
94124

PABLODESIGNS.COM
PABLODESIGNS.EU

Pablo®

MULTI-LIGHT CANOPY

9" and 12"

SKY DOME & SKY SOUND

ASSEMBLY & INSTALLATION INSTRUCTIONS



Pablo® MULTI-LIGHT CANOPY

- 1** LOCATE BUILDING POWER FEED/JUNCTION BOX
DETERMINE AND MARK SWAG LOCATIONS REFERENCING THE DIAGRAM AND PROVIDED CHART.
PROVIDED LAMP WIRES ARE 10', LAMP HANG HEIGHT REDUCES IN RELATION TO SWAG DISTANCE FROM CANOPY.

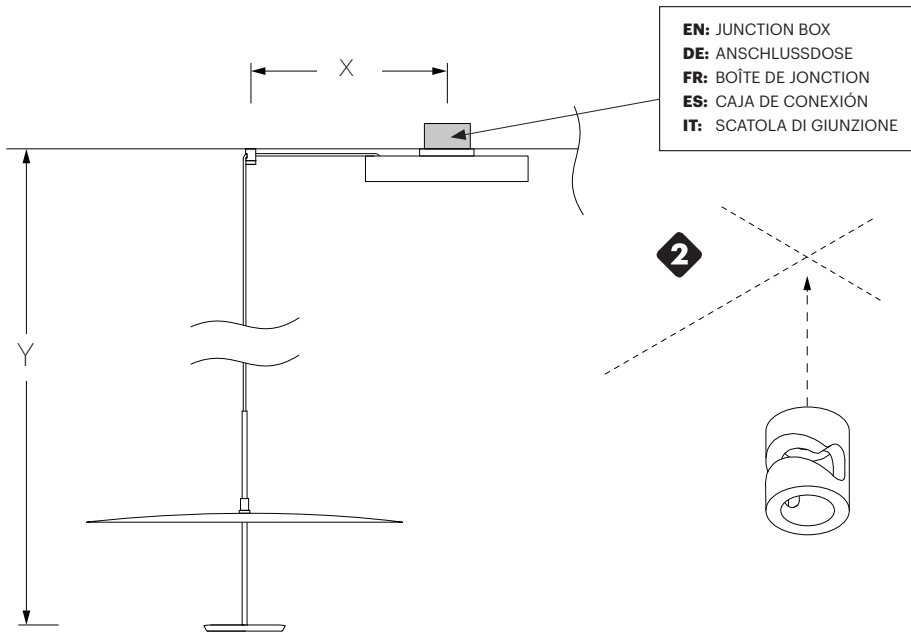

PROVIDED LAMP WIRES ARE 10', LAMP HANG HEIGHT REDUCES IN RELATION TO SWAG DISTANCE FROM CANOPY. IF X=5', Y CAN BE A MAXIMUM OF 5'.

SWAG SPACING CENTER TO CENTER		SKY 18	SKY 24	SKY 32
		SKY 18	9" 22.8 CM	12.25" 31 CM
SKY 24	12.25" 31 CM	12.25" 31 CM	16.25" 41.3 CM	
SKY 32	16.25" 41.3 CM	16.25" 41.3 CM	16.25" 41.3 CM	

Pablo® MULTI-LIGHT CANOPY

- 3** REMOVE CANOPY COVER, SET ASIDE

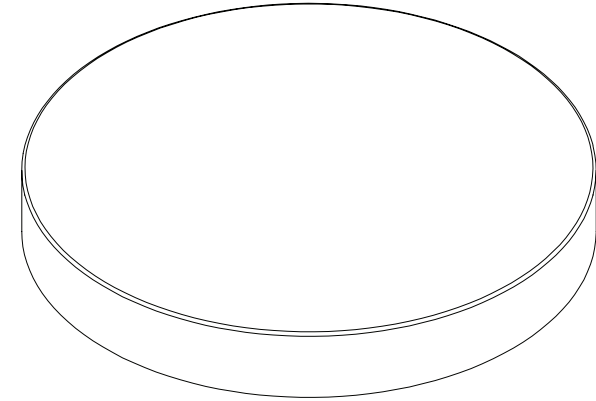

- 4** REMOVE DRIVER PLATE BY
REMOVING 3X FLAT HEAD SCREWS

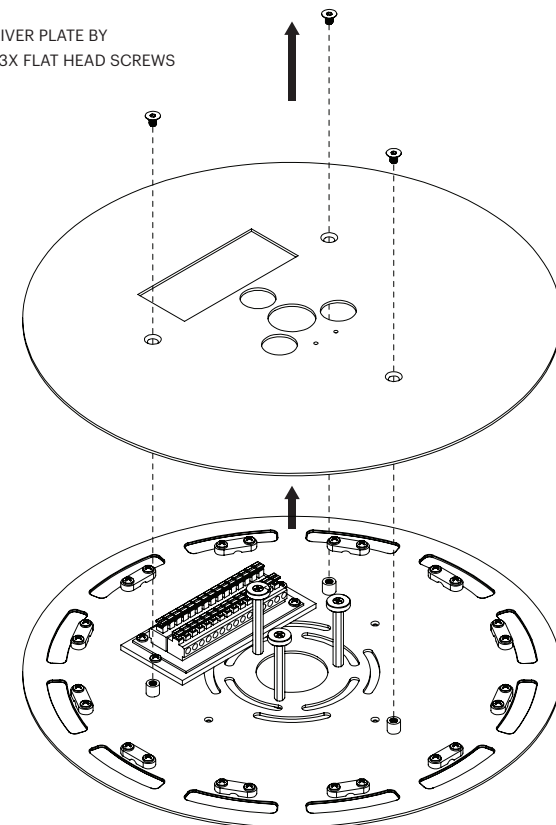

Pablo® MULTI-LIGHT CANOPY

5 ROUTE BUILDING WIRING THROUGH MOUNTING PLATE.

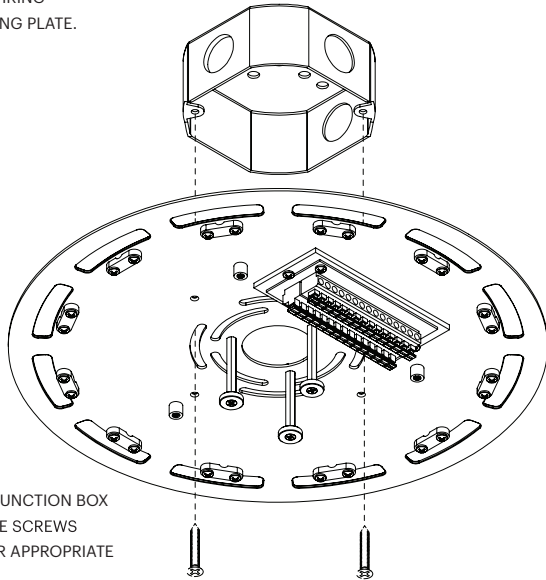

6 ATTACH PLATE TO JUNCTION BOX WITH 8-32 MACHINE SCREWS (NOT PROVIDED) OR APPROPRIATE ANCHORS.

7 WIRE BUILDING WIRING TO TERMINAL BLOCK.
US: BLACK TO BLACK AND WHITE TO WHITE **EU:** BLUE TO WHITE BROWN TO BLACK.

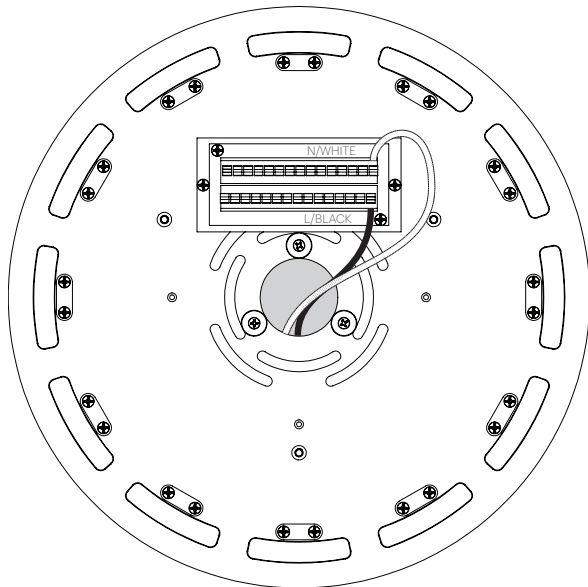

Pablo® MULTI-LIGHT CANOPY

8 REMOVE THREADED SWAG CAP

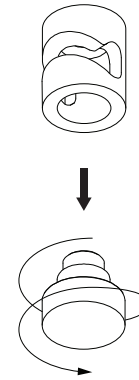

9 MOUNT SWAG USING APPROPRIATE FASTENER AND ANCHOR IN MARKED LOCATION

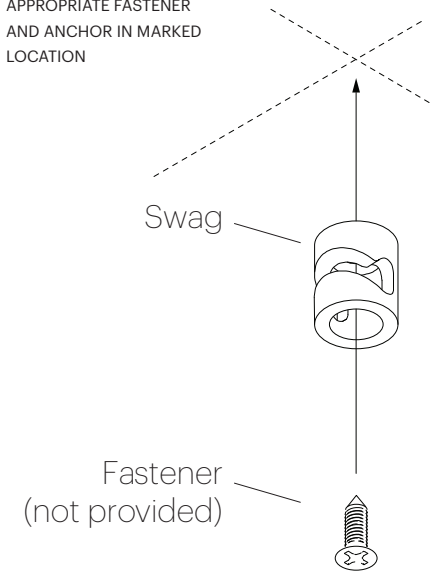

NOTE: Cable slot should face canopy center point.

 Cable slot

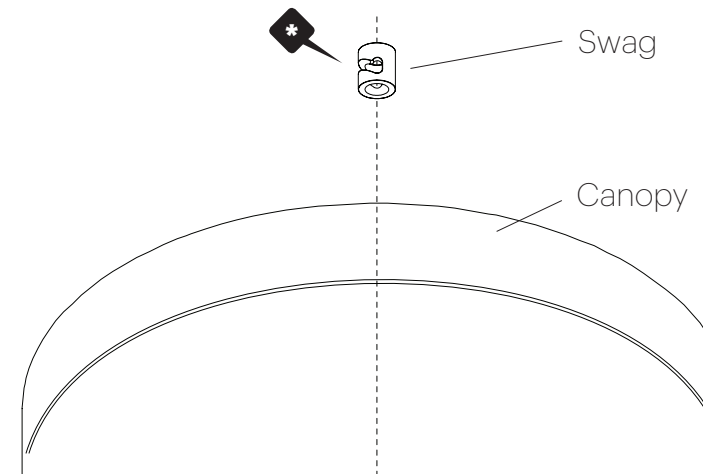

Pablo® MULTI-LIGHT CANOPY

***** SKY: ASSEMBLE SHADE AND LIGHT ENGINE

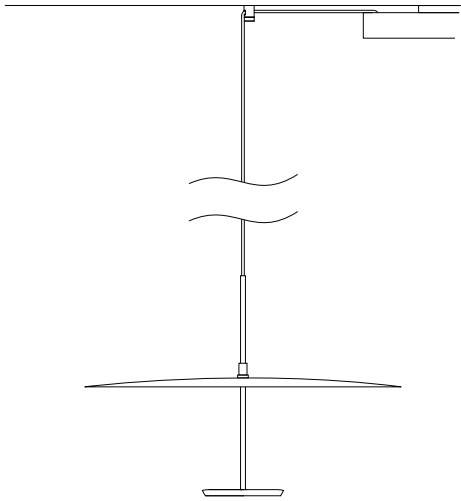

USE PROVIDED GLOVES WHEN HANDLING LAMP TO AVOID FINGER MARKS.

10 PLACE WIRE IN SWAG. MAKE SURE WIRE IS IN CHANNEL

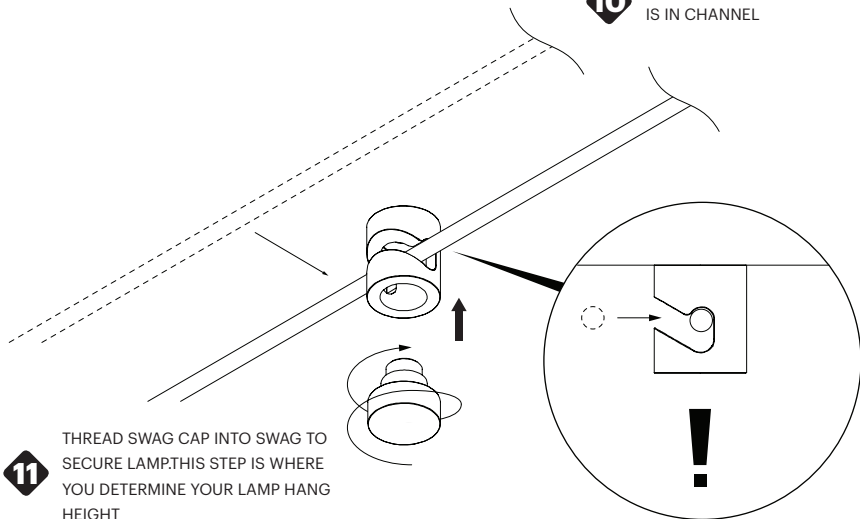

11 THREAD SWAG CAP INTO SWAG TO SECURE LAMP. THIS STEP IS WHERE YOU DETERMINE YOUR LAMP HANG HEIGHT

Pablo® MULTI-LIGHT CANOPY

12 THREAD WIRE THROUGH MOUNT PLATE

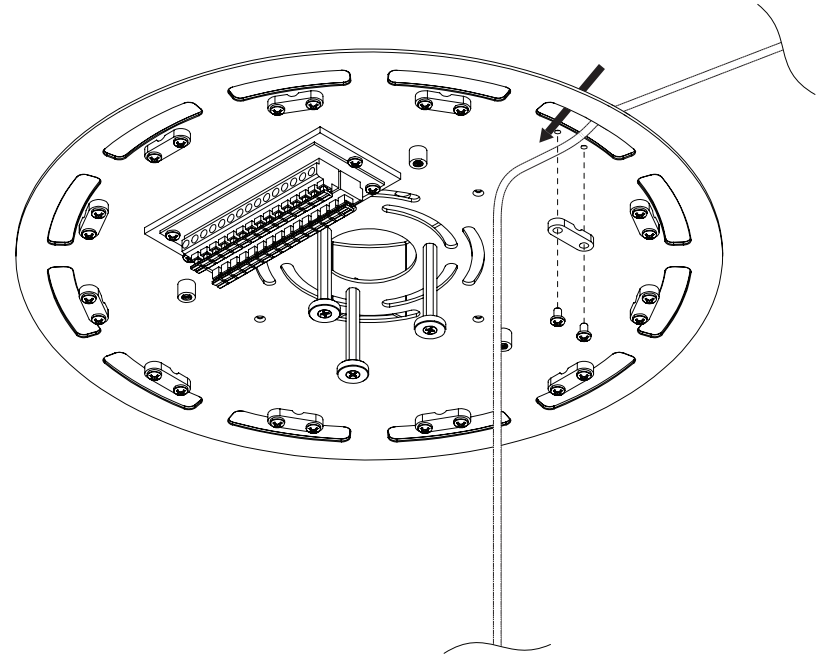

13 **A** PULL WIRE TAUGHT AND STRAIN RELIEVE

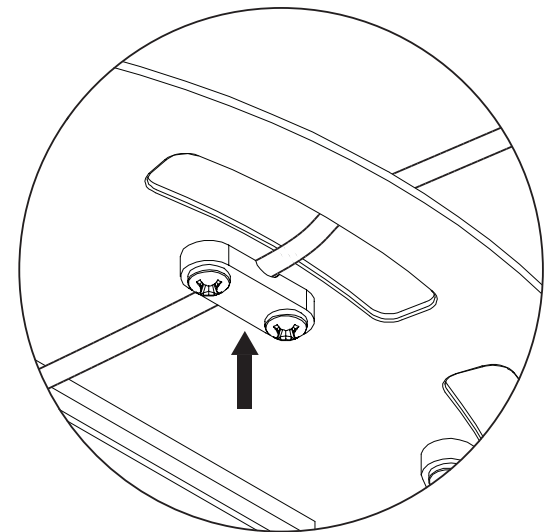

Pablo® MULTI-LIGHT CANOPY

13

B REMOVE PLUG

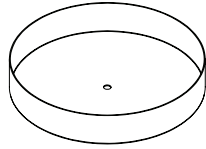

B PLACE CANOPY COVER BAG OVER CANOPY

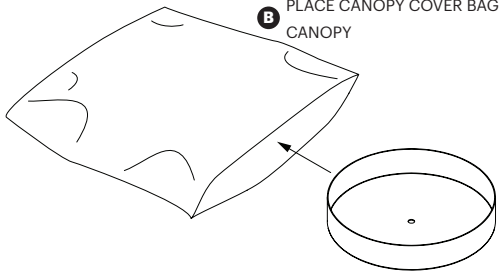

C USING A PENCIL, PUNCTURE SMALL HOLE FOR WIRE TO PASS THROUGH

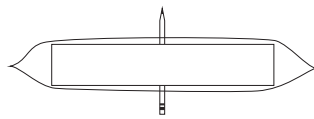

D THREAD WIRE THROUGH CANOPY AND CENTER OF DRIVER-PLATE

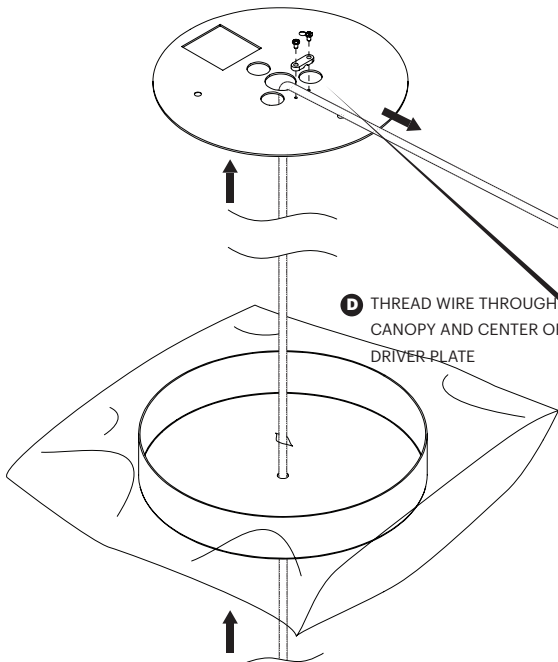

E

STRAIN RELIEVE WIRE ON DRIVER PLATE
NOTE FOR BOLA: THIS IS WHEN YOU SET YOUR HANG HEIGHT

F TIE KNOT JUST PAST STRAIN RELIEF

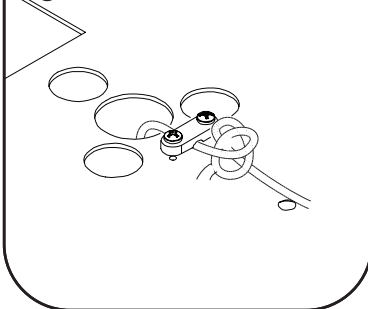

Pablo® MULTI-LIGHT CANOPY

14

ATTACH DRIVER PLATE TO MOUNT PLATE WITH PROVIDED FLAT HEAD SCREWS
THREAD WIRES THROUGH CENTER OF DRIVER PLATE

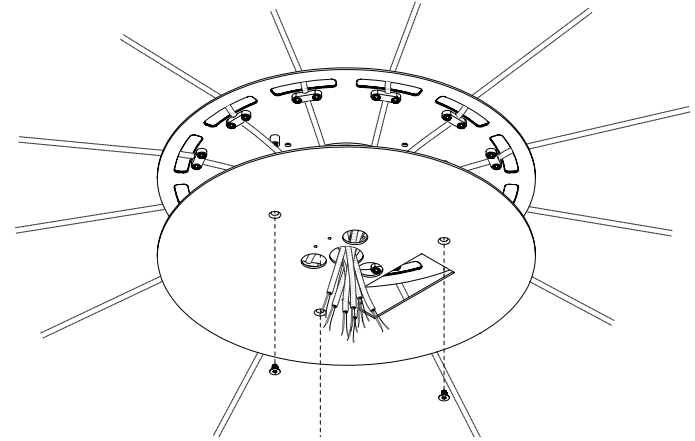

15

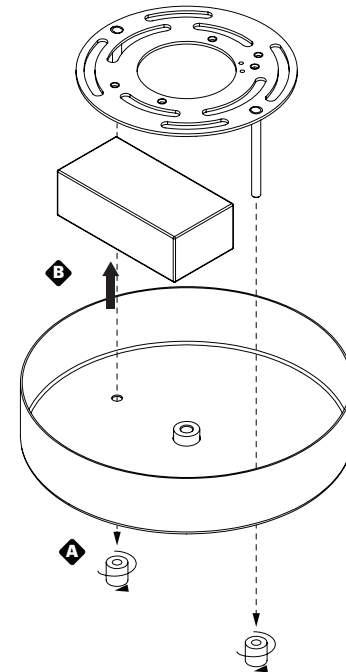

REMOVE INDIVIDUAL LAMP DRIVERS FROM INDIVIDUAL LAMP CANOPIES

MULTI-LIGHT CANOPY

16 PEEL LINER OFF OF VHB TAPE

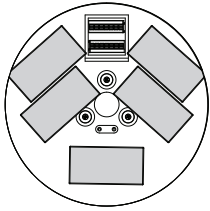
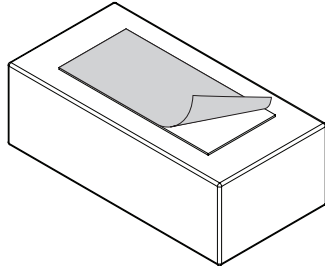

9" CANOPY
MAXIMUM
CAPACITY

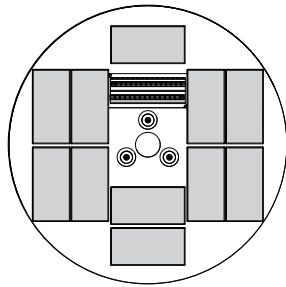

12" CANOPY
MAXIMUM
CAPACITY

17 ATTACH DRIVERS TO DRIVER PLATE

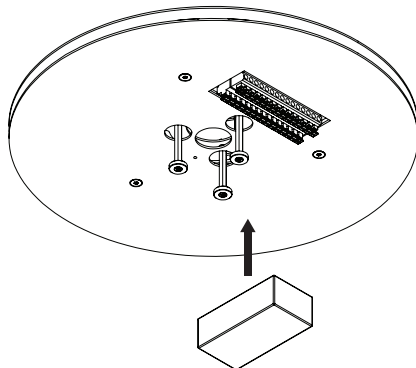

MULTI-LIGHT CANOPY

18 CONNECT DRIVERS TO TERMINAL BLOCK.
US: BLACK TO BLACK AND WHITE TO WHITE **EU:** BLUE TO BLUE AN BROWN TO BROWN

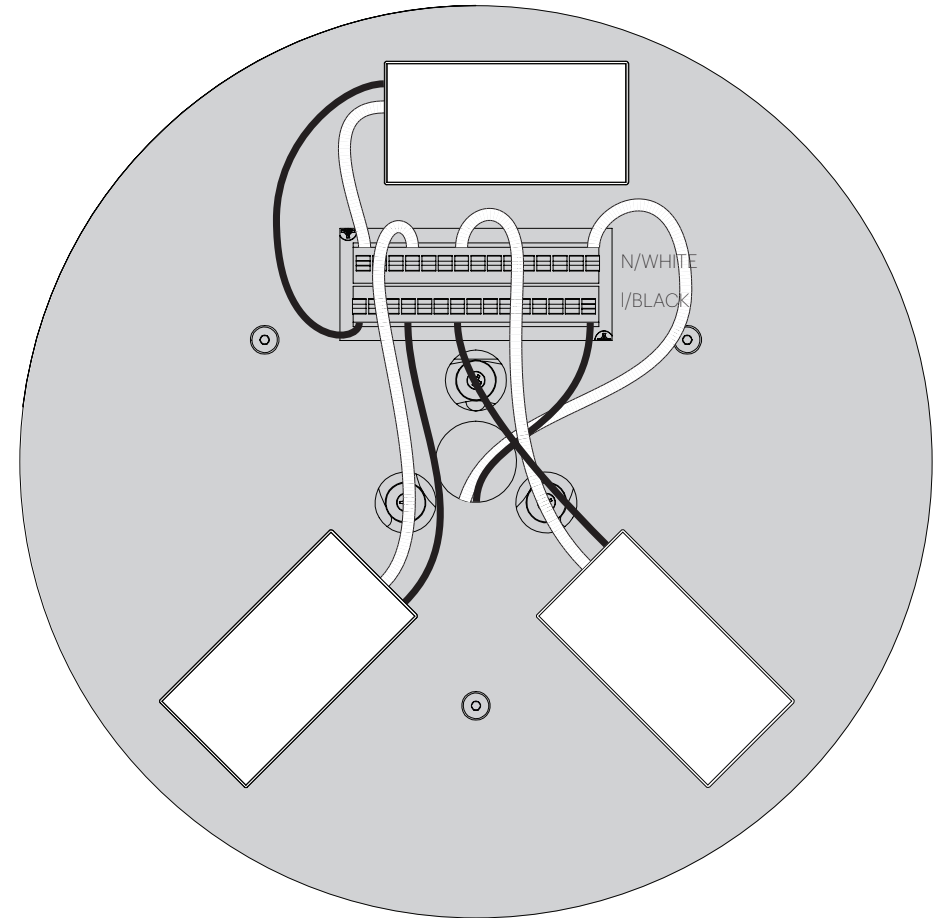

Pablo® MULTI-LIGHT CANOPY

19 ONE AT A TIME, WIRE LAMPS TO MATCHING DRIVERS. CUT EXCESS WIRE IF NECESSARY

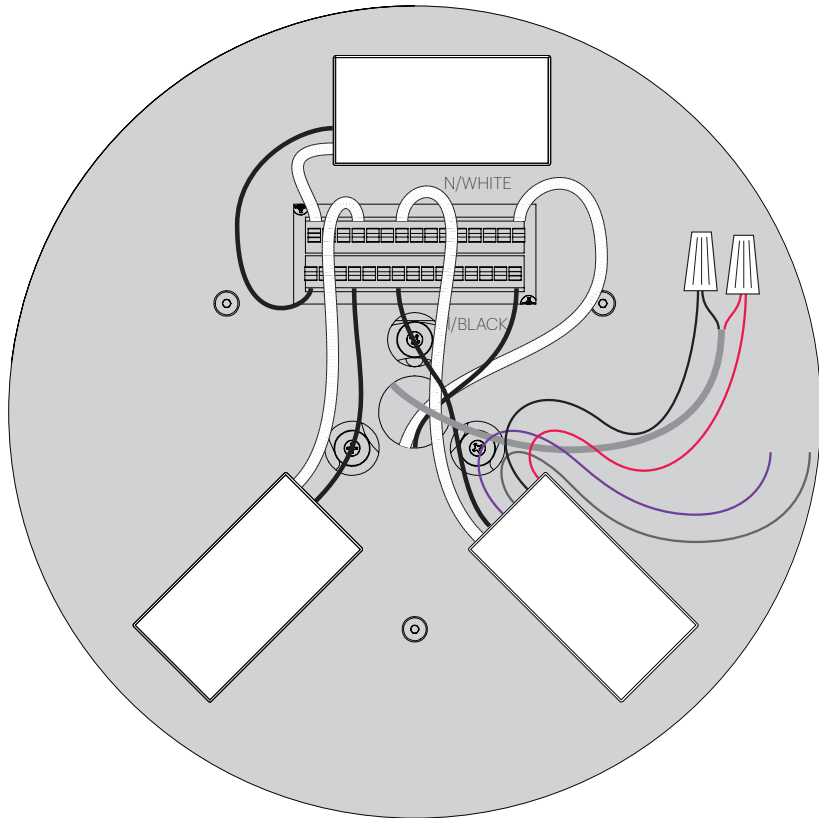

! IF USING 0-10V DIMMING, WIRE DIMMING IN PARALLEL

Pablo® MULTI-LIGHT CANOPY

20 ATTACH CANOPY COVER

CARE INSTRUCTIONS

WIPE CLEAN WITH A SOFT DAMP CLOTH. AVOID AMMONIA BASED CLEANER.

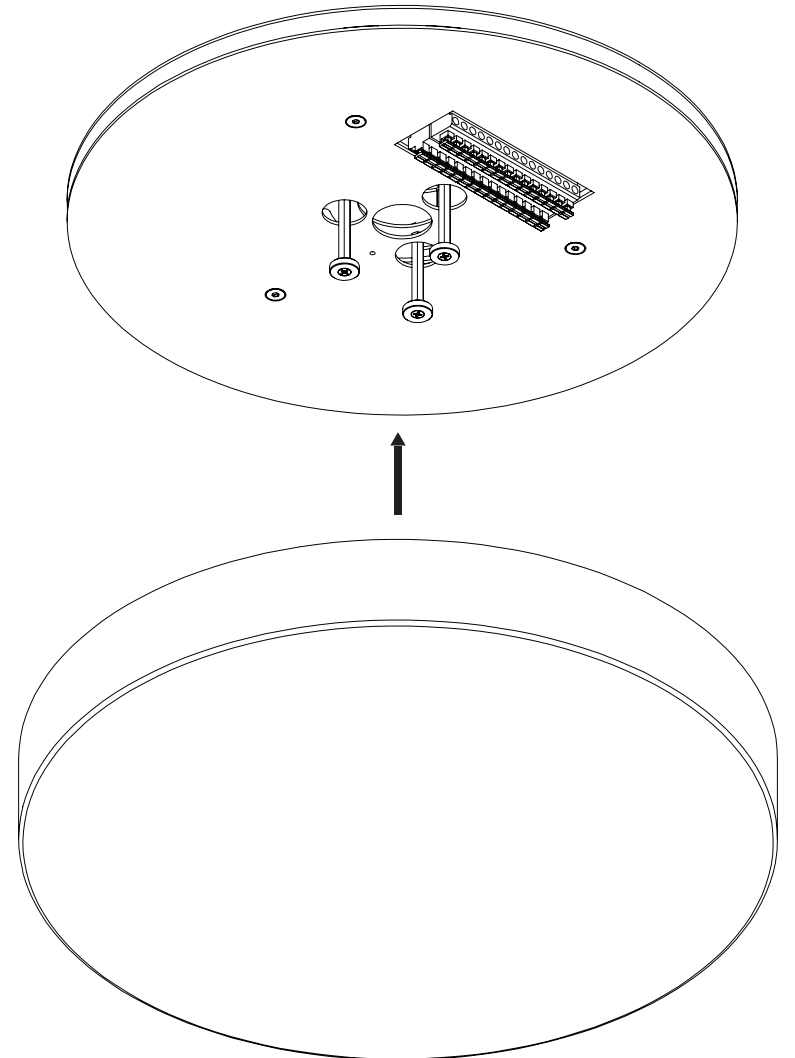

USE PROVIDED GLOVES WHEN HANDLING LAMP TO AVOID FINGER MARKS.