



**daide groppi**

INSTRUCTIONS

**BUBKA**

DESIGN DANIELE SPREGA - 2014

MADE IN PIACENZA

MADE IN ITALY



Luce per vedere, luce per sentire.

IT - Grazie per aver scelto una lampada Davide Groppi.  
Semplicità, leggerezza, emozione, invenzione e stupore sono le componenti fondamentali dei nostri progetti.

EN - Thank you for choosing a Davide Groppi light.  
Simplicity, weightlessness, emotion, creative invention, amazement are the fundamental components of our designs.

FR - Merci d'avoir choisi une lampe Davide Groppi.  
La simplicité, légèreté, émotion, invention et surprise sont l'essence de nos projets.

DE - Danke, dass Sie sich für eine Lampe von Davide Groppi entschieden haben. Einfachheit, Leichtigkeit, Emotion, Erfindung und Erstaunen sind die grundlegenden Elemente unserer Projekte.

ES - Gracias por haber elegido una lámpara Davide Groppi.  
Sencillez, ligereza, emoción, invención y asombro son los componentes fundamentales de nuestros proyectos.

PT - Obrigado por escolher um candeeiro Davide Groppi.  
Simplicidade, delicadeza, emoção, inovação e deslumbramento são as peças fundamentais dos nossos projectos.

RU - Благодарим за выбор светильника Davide Groppi.  
Простота, легкость, эмоции, креатив и умение удивлять – вот основные составляющие наших проектов.

ZH - 非常感谢您选用 Davide Groppi 品牌灯具。  
简洁、轻盈、激情、创意和宏伟, 构成了我们设计理念的基本要素。

AR - نشكركم لاختياركم مصباح Davide Groppi .  
البساطة، الخفة، العاطفة، الاختراع، والدهشة هي المكونات الأساسية لمشاريعنا.

IT - Le descrizioni dei simboli relativi a questa lampada si trovano sul foglio legenda allegato.

EN - The descriptions of the symbols relating to this light are found on the legend sheet attached.

FR - Les descriptions des symboles relatifs à cette lampe se trouvent sur la légende fournie en annexe.

DE - Die Beschreibungen der Symbole für diese Lampe finden Sie auf dem beigefügten Blatt der Zeichenerklärungen.

ES - Las descripciones de los símbolos relacionados con esta lámpara se pueden encontrar en la hoja de leyenda adjunta.

PT - As descrições dos símbolos relativos a essa lâmpada encontram-se na folha de legenda em anexo.

RU - Описание символов, относящихся к этой лампе находится в приложении с условными обозначениями.

ZH - 灯具所使用的符号描述, 可参阅附件说明书。

AR - يمكن العثور على أوصاف الرموز المتعلقة بهذا المصباح على ورقة الرموز المرفقة.

Bubka LED spot  
Code 1A361XX00A.XX.20  
Max 8,4 W LED module - Max 700 mA  $\equiv$  DC  
Uout < 60 V  $\equiv$  DC  
**ta 25°C**

Bubka LED spot  
Code 1851XX03\*  
LED luminaire  
CLASS 2  
Max 8,4 W LED module - Max 700 mA  $\equiv$  DC  
Uout < 60 V  $\equiv$  DC  
**ta 25°C**

Suitable for wet locations  
Convient aux emplacements mouillés

Use only with Davide Groppi luminaires kits  
Bubka - code 1A360-1739  
Bubka Bollard - code 1A144

Optional installation kits  
Anchoring bolt - Code 1A362-1773

\*cETLus certification



IP65

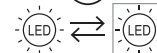

## IT - Istruzioni di installazione ed impiego.

### Attenzione

La sicurezza dell'apparecchio è garantita solo rispettando queste istruzioni sia in fase di installazione che di impiego. È necessario conservarle.

- All'atto dell'installazione ed ogni volta che si interviene sull'apparecchio, assicurarsi che sia stata tolta la tensione di alimentazione.

- L'apparecchio non può essere in alcun modo modificato o manomesso, ogni modifica ne può compromettere la sicurezza rendendo lo stesso pericoloso. Davide Groppi srl declina ogni responsabilità per i prodotti modificati.

## EN - Installation and use instructions.

### Attention

Safety of the appliance is only guaranteed by complying with these instructions both during the installation and use phase. They must be kept.

- On installation and each time you intervene on the appliance, ensuring the power supply was disconnected.

- The appliance cannot be altered or tampered with in any way, any changes would compromise safety, making it dangerous. Davide Groppi srl cannot be held in any way liable for altered products.

## FR - Instructions pour l'installation et l'utilisation.

### Attention

La sécurité de l'appareil peut uniquement être garantie en respectant ces instructions, aussi bien lors de l'installation que lors de l'utilisation.

Il est nécessaire de les conserver.

- S'assurer que la tension d'alimentation a été coupée avant de procéder à l'installation et à une intervention sur l'appareil.

- L'appareil ne peut en aucun cas être modifié ni manipulé ; toute modification peut en compromettre la sécurité et le rendre dangereux. Davide Groppi srl décline toute responsabilité pour les produits modifiés.

## DE - Installations- und Bedienungsanleitung.

### Achtung

Die Sicherheit des Gerätes ist nur gewährleistet, wenn diese Anweisungen sowohl bei der Installation als auch beim Gebrauch beachtet werden.

Diese Anweisungen müssen aufbewahrt werden.

- Stellen Sie bei der Installation und bei jedem Eingriff am Gerät sicher, dass die Stromversorgung unterbrochen ist.

- Das Gerät darf nicht verändert oder manipuliert werden. Änderungen können die Sicherheit beeinträchtigen und eine Gefahr darstellen. Davide Groppi srl lehnt jegliche Haftung für veränderte Produkte ab.

## ES - Instrucciones de instalación y de uso.

### Atención

La seguridad del aparato sólo se garantiza si se siguen estas instrucciones durante la instalación y el uso.

Es necesario mantenerlas.

- Cuando se instale y cada vez que intervenga en el aparato, asegúrese de que la tensión de alimentación ha sido desconectada.

- El aparato no puede ser modificado o alterado de ninguna manera, cualquier modificación puede comprometer la seguridad y hacerlo peligroso. Davide Groppi srl declina toda responsabilidad por los productos modificados.

## PT - Instruções de instalação e emprego.

### Atenção

A segurança do aparelho é garantida apenas respeitando essas instruções tanto na fase de instalação quanto naquela de emprego.

É necessário conservá-las.

- No ato de instalação e toda vez que for necessário intervir no aparelho, assegurar-se de que tenha sido removida a tensão de alimentação.

- O aparelho não pode ser modificado ou adulterado em nenhum modo, qualquer modificação pode comprometer a sua segurança, tornando o mesmo perigoso.

Davide Groppi srl declina qualquer responsabilidade pelos produtos modificados.

## RU - Инструкции по установке и использованию.

### Внимание

Безопасность аппарата гарантируется только при соблюдении этих инструкций как при установке, так и при использовании.

Необходимо их сохранять.

- При установке и всякий раз при проведении операций с аппаратом, убедитесь, что отключено напряжение питания.

- Ни в коем случае нельзя модифицировать или вмешиваться в работу аппарата, любое изменение может поставить под угрозу его надежность, делая его небезопасным.

Компания Davide Groppi srl снимает с себя любую ответственность за измененные продукты.

## ZH - 安装及使用说明

### 注意

只有在遵守安装及使用阶段的说明情况下,才可保证电器的安全。必须将本文件妥为保存。

- 每当安装电器以及使用操作电器时,请确保电源电压已经断开。

- 电器不得以任何方式修改或篡改,任何修改都有可能损害其安全性能,产生危险。

Davide Groppi srl 拒绝承担任何修改产品导致的任何责任。

AR - تعليمات التركيب والاستخدام.

تنبيه

يتم ضمان سلامة الجهاز فقط من خلال مراعاة هذه التعليمات أثناء التركيب والاستخدام. ينبغي الالتزام بها.

- عند التركيب وكلما يحدث تدخل في الجهاز, تأكد من أنك قمت بفصل التيار الكهربائي.

- لا يمكن تعديل الجهاز أو العبث به بأي طريقة, إن أي تعديل يمكن أن يقوض سلامته ويجعله خطيرًا.

تُعفى Davide Groppi srl من أي مسؤولية عن المنتجات المعدلة.

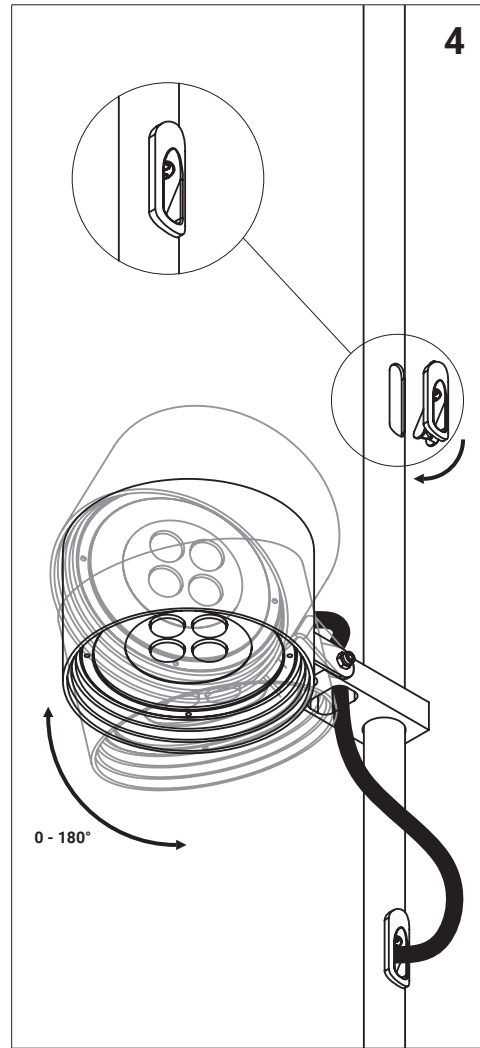
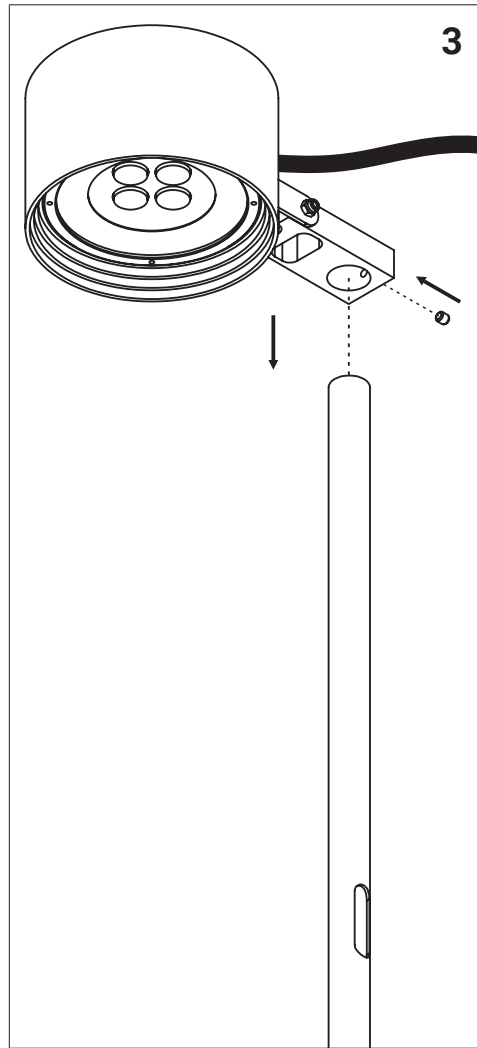
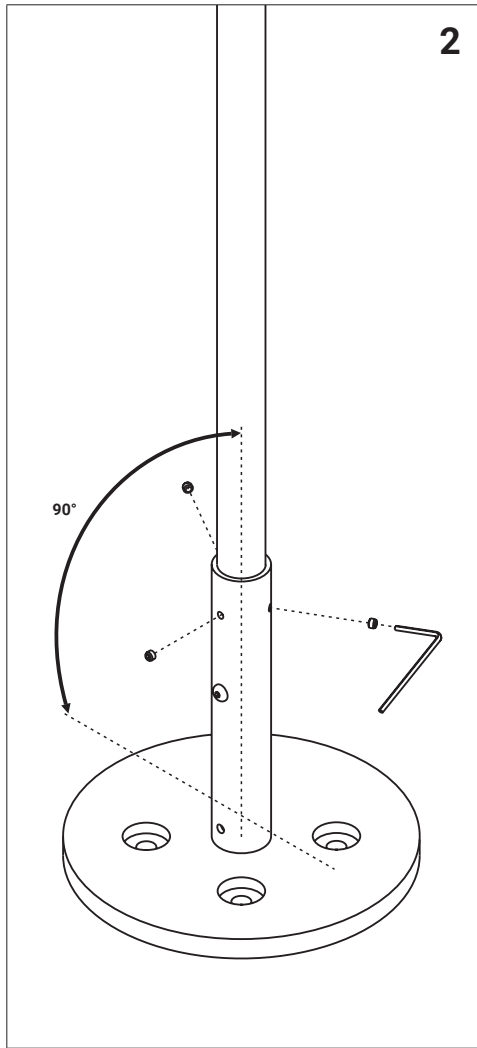
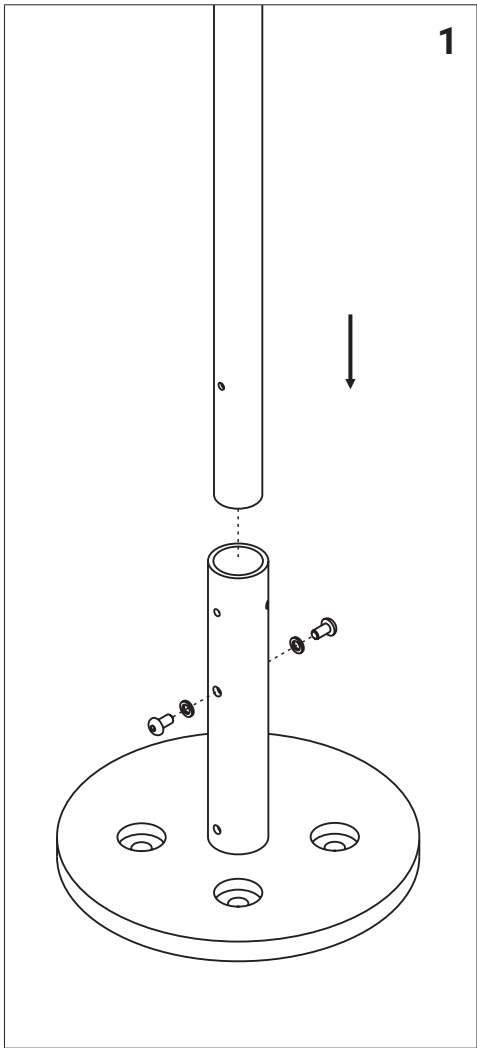

5

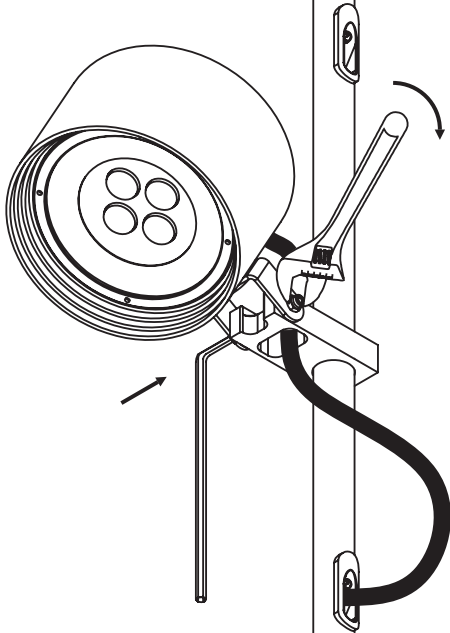

6

Max 1 cable for grommets

Max 2

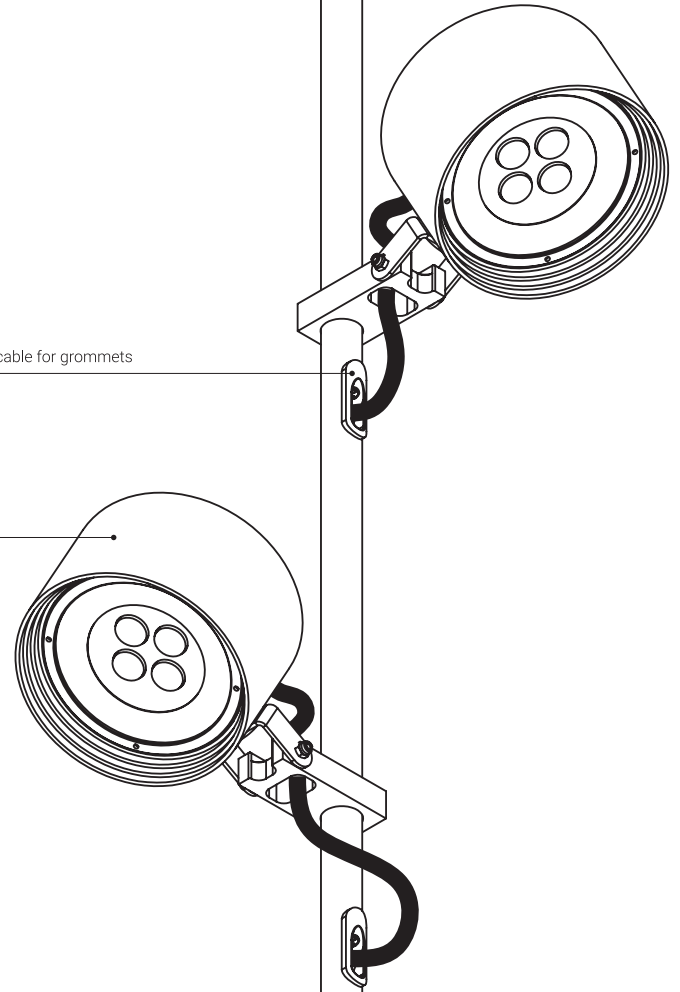

## EU Version - Installation with recessed cable

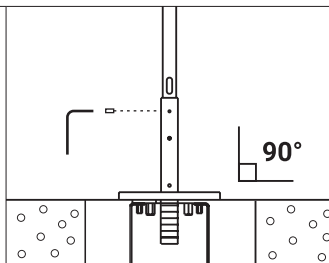
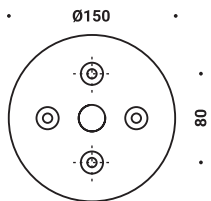
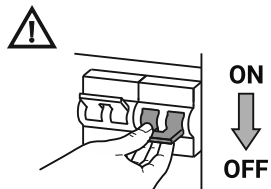

### Without anchoring bolt

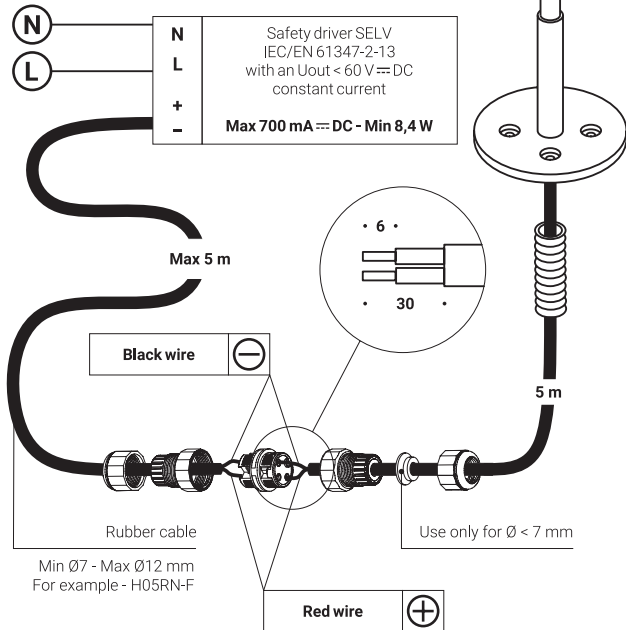

### With anchoring bolt

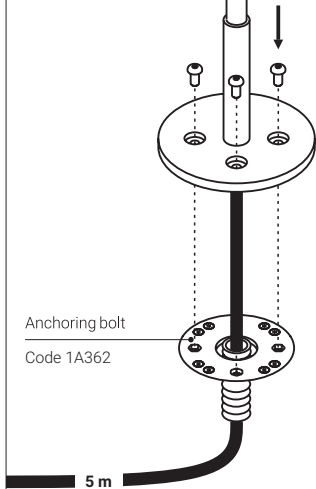

## EU Version - Installation with recessed cable

### Connector included

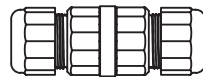

### 1A360 - Driver LED not included

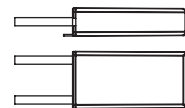

• 400 • 122 •

### 1A144 - Driver LED not included

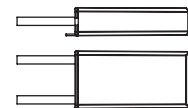

• 400 • 122 •

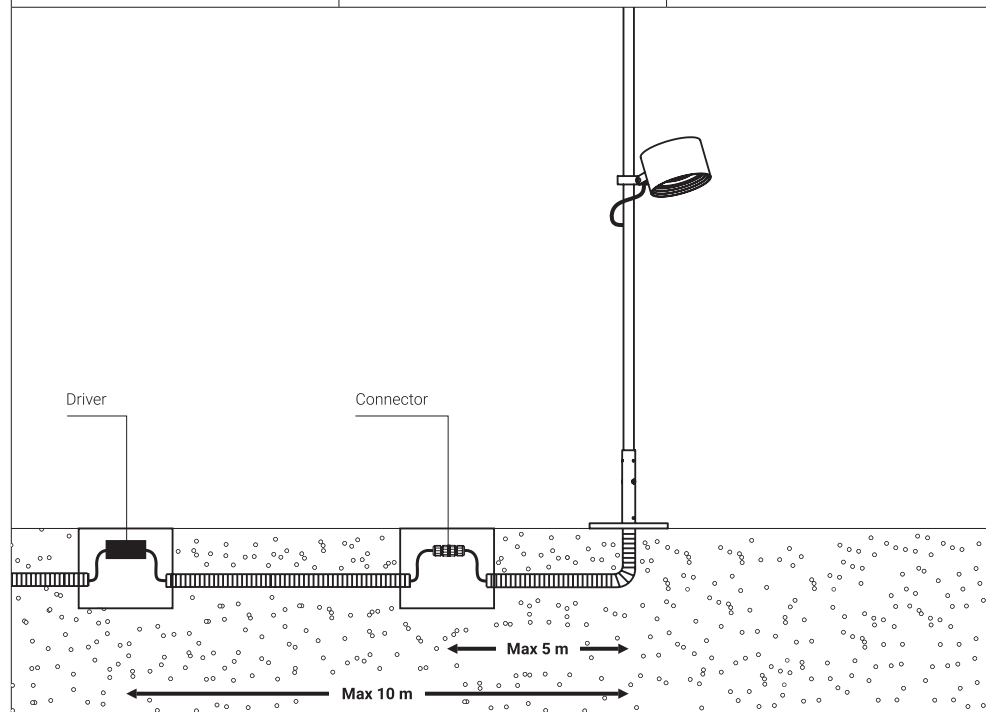

## EU Version - Installation with not recessed cable

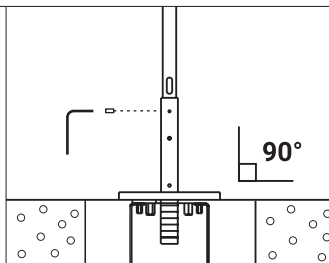
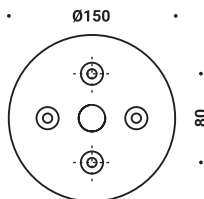
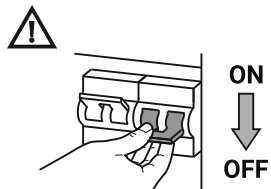

### Without anchoring bolt

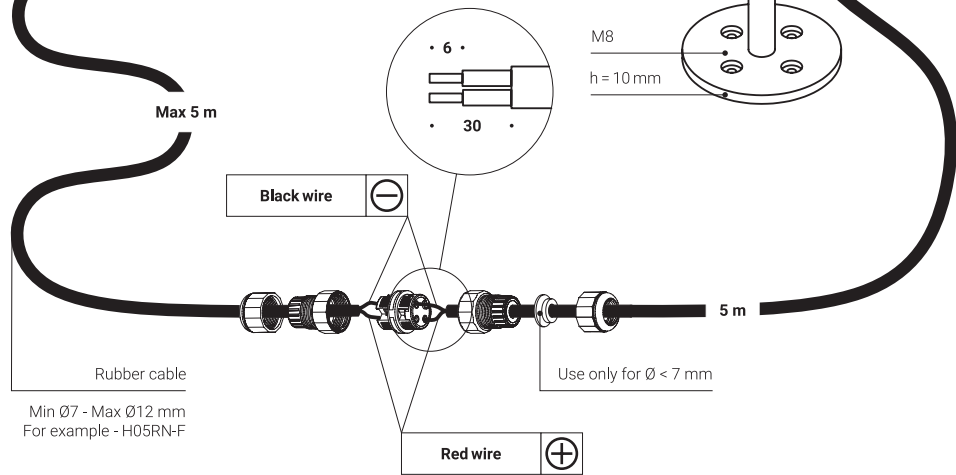
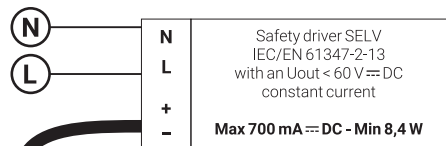

## EU Version - Installation with not recessed cable

To connect two or more lamps (max 4 lamps), only serial connection is allowed

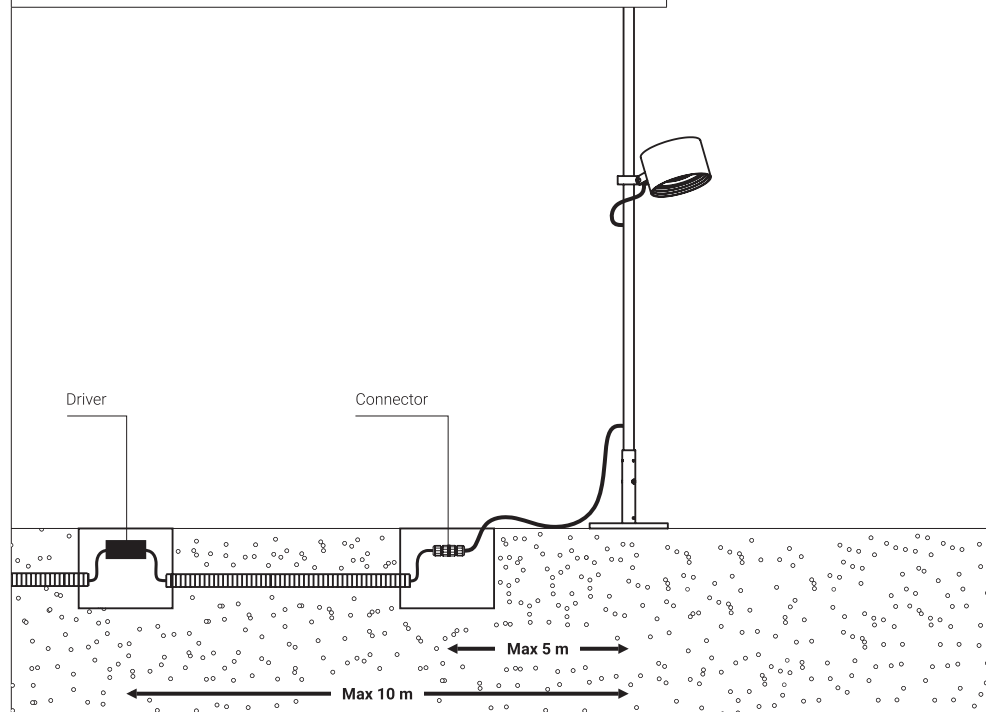
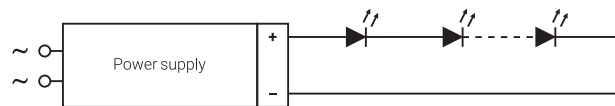

## US Version - Installation with recessed cable

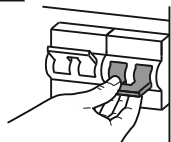

**ON**  
↓  
**OFF**

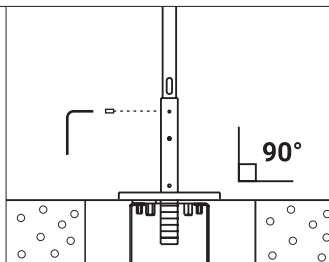
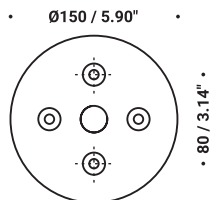

**Without anchoring bolt**

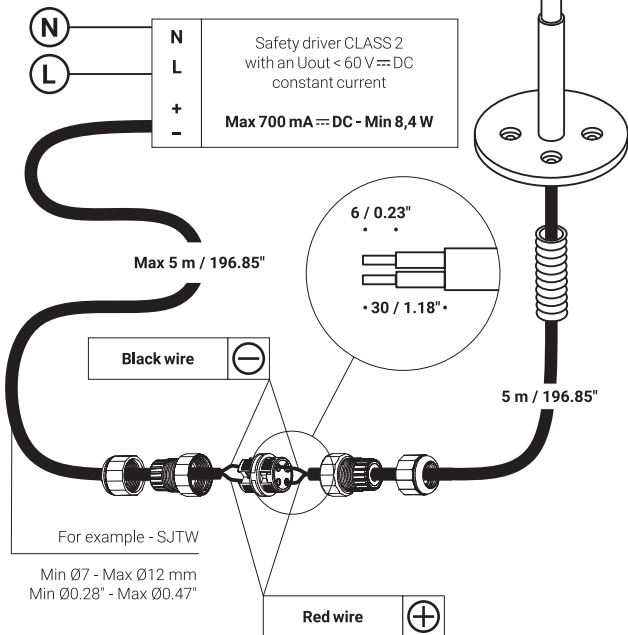

**With anchoring bolt**

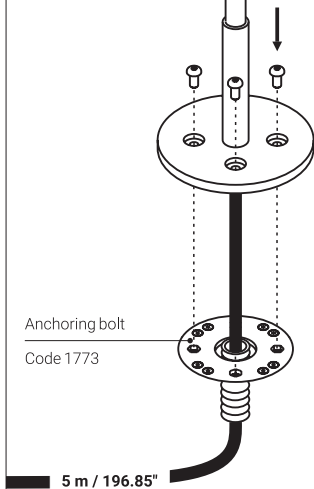

## US Version - Installation with recessed cable

**Connector not included**

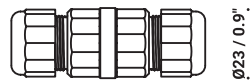

68 / 2.67"

**EN - Attention**

The connector used for connecting the lamp to the LED driver shall comply with UL / CSA requirements for outdoor use.

**FR - Attention**

Le connecteur utilisé pour connecter le voyant au pilote de la LED devra être conforme aux exigences UL / CSA pour une utilisation en extérieur.

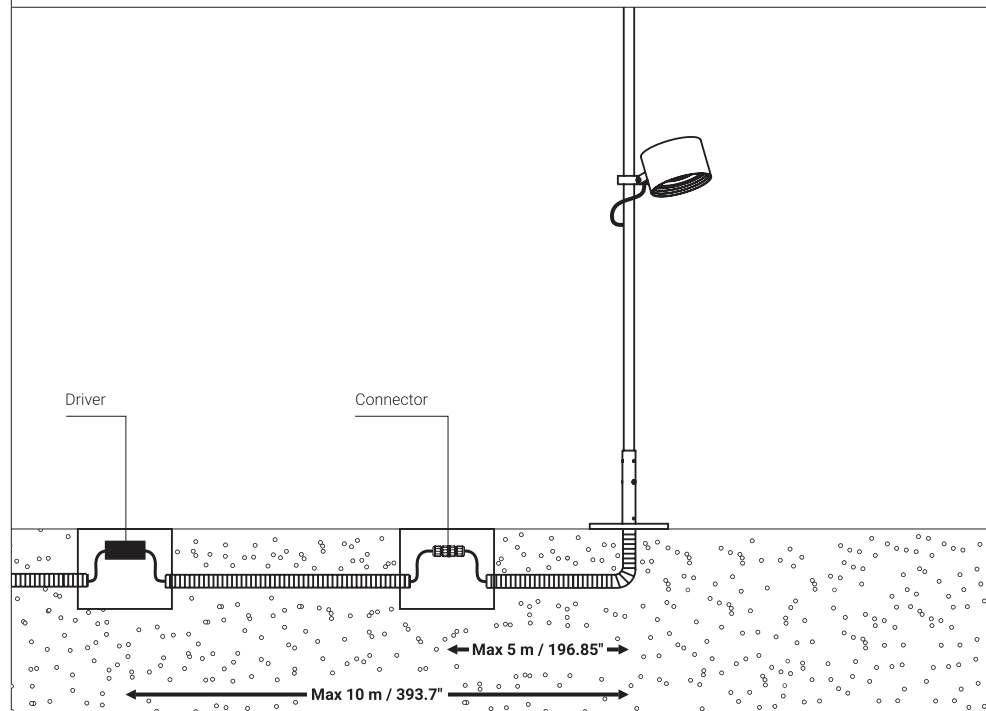



## US Version - Installation with not recessed cable

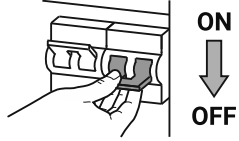

ON  
OFF

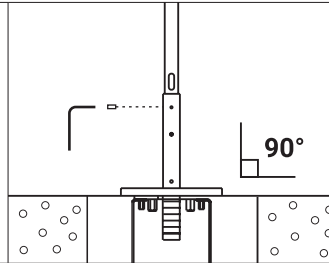
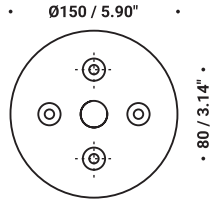

Without anchoring bolt

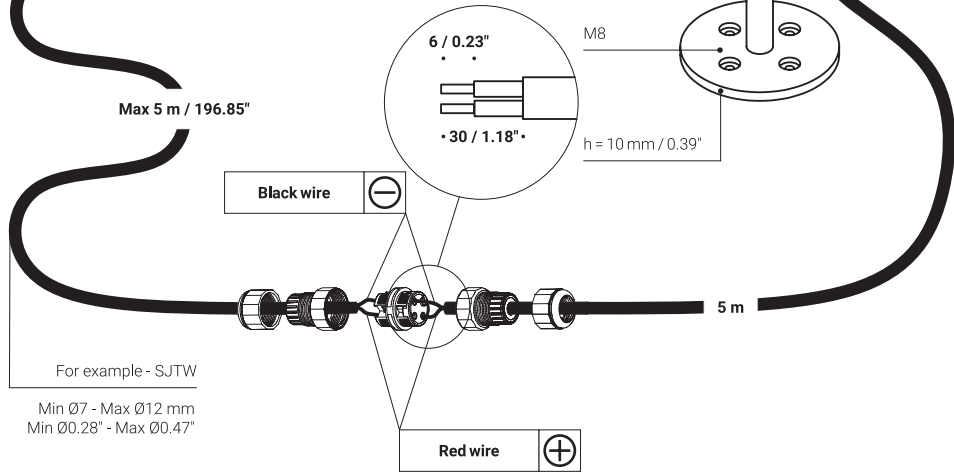
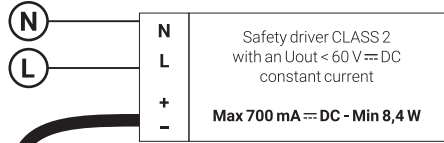

For example - SJTW

Min Ø7 - Max Ø12 mm  
Min Ø0.28" - Max Ø0.47"

## US Version - Installation with not recessed cable

To connect two or more lamps (max 4 lamps), only serial connection is allowed

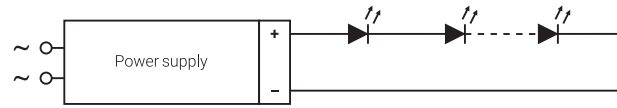

1739 - 1A144 - Driver LED included

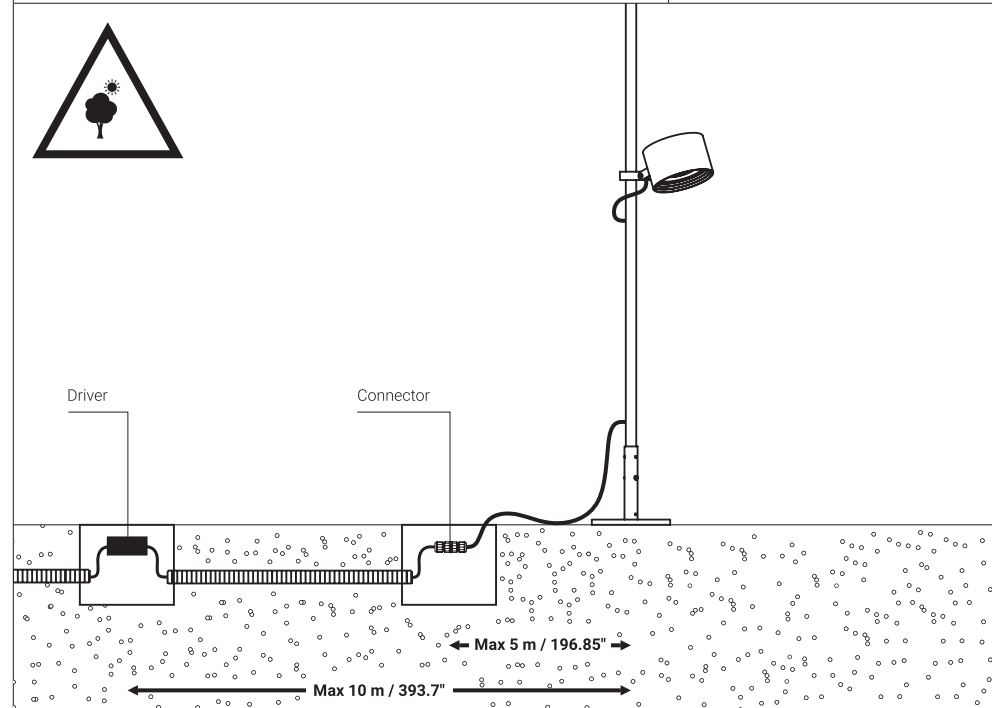
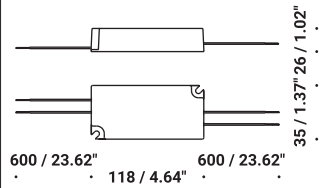

**Example of ceiling installation**

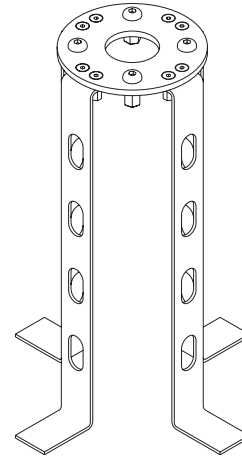
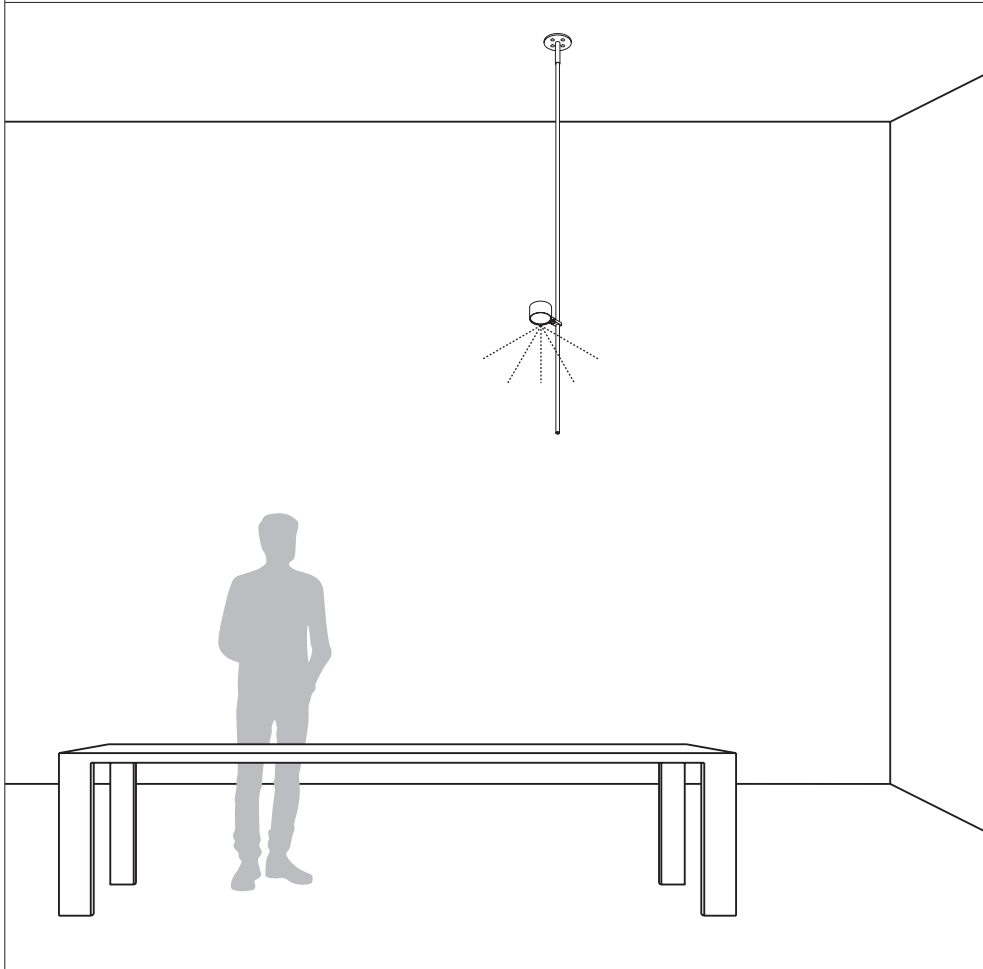

**daide groppi**

INSTRUCTIONS

**ANCHORING BOLT**  
OPTIONAL INSTALLATION KITS  
MADE IN PIACENZA  
MADE IN ITALY

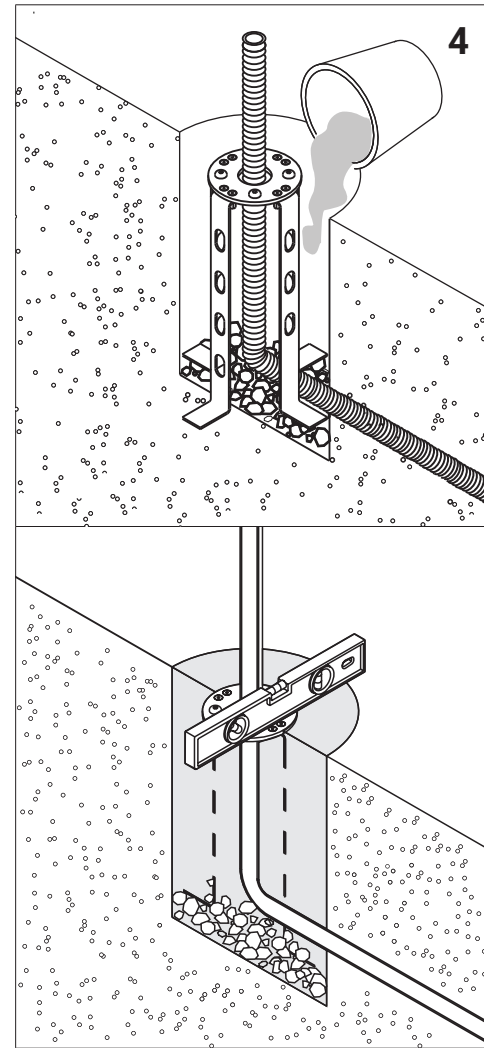
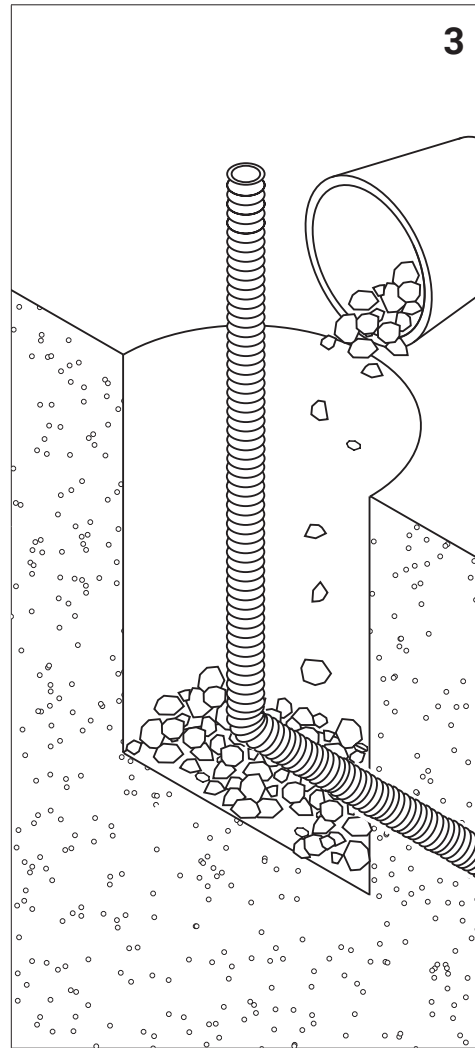
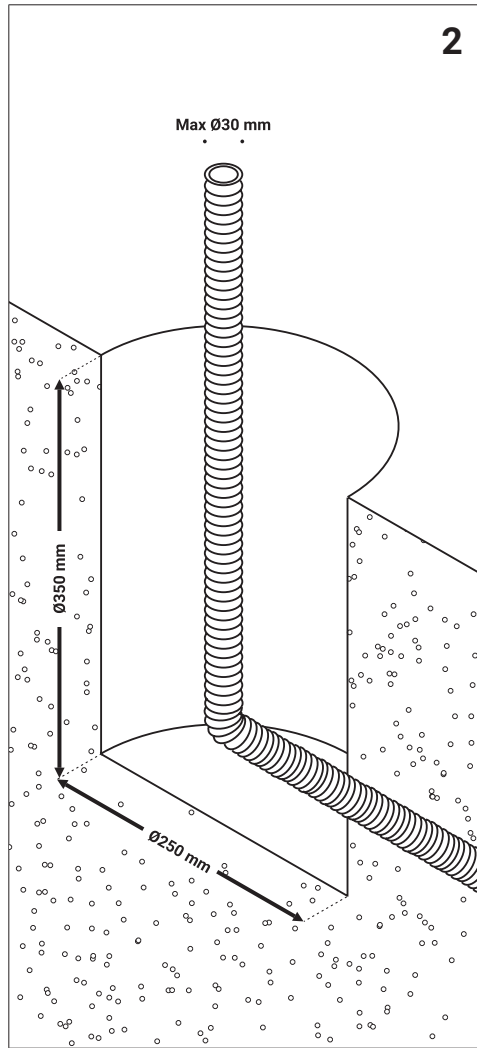
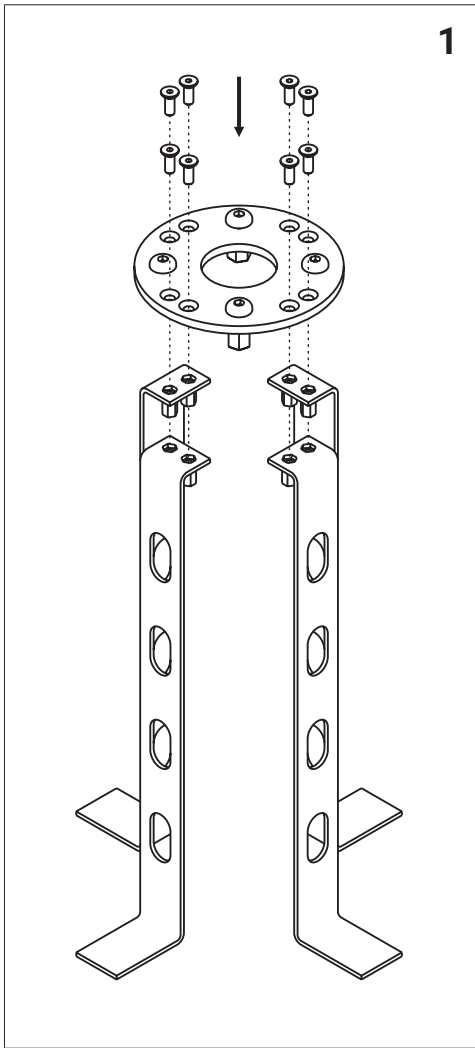

5

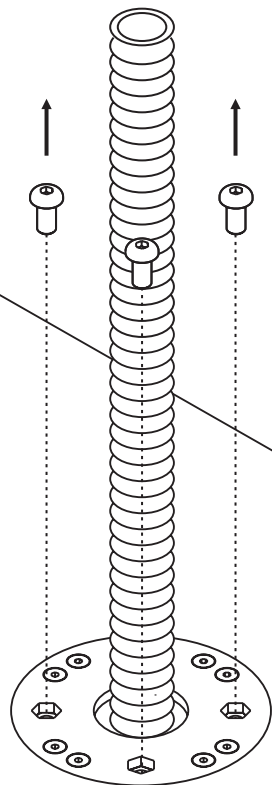

6

Code 1A360 - 1739

Code 1A144

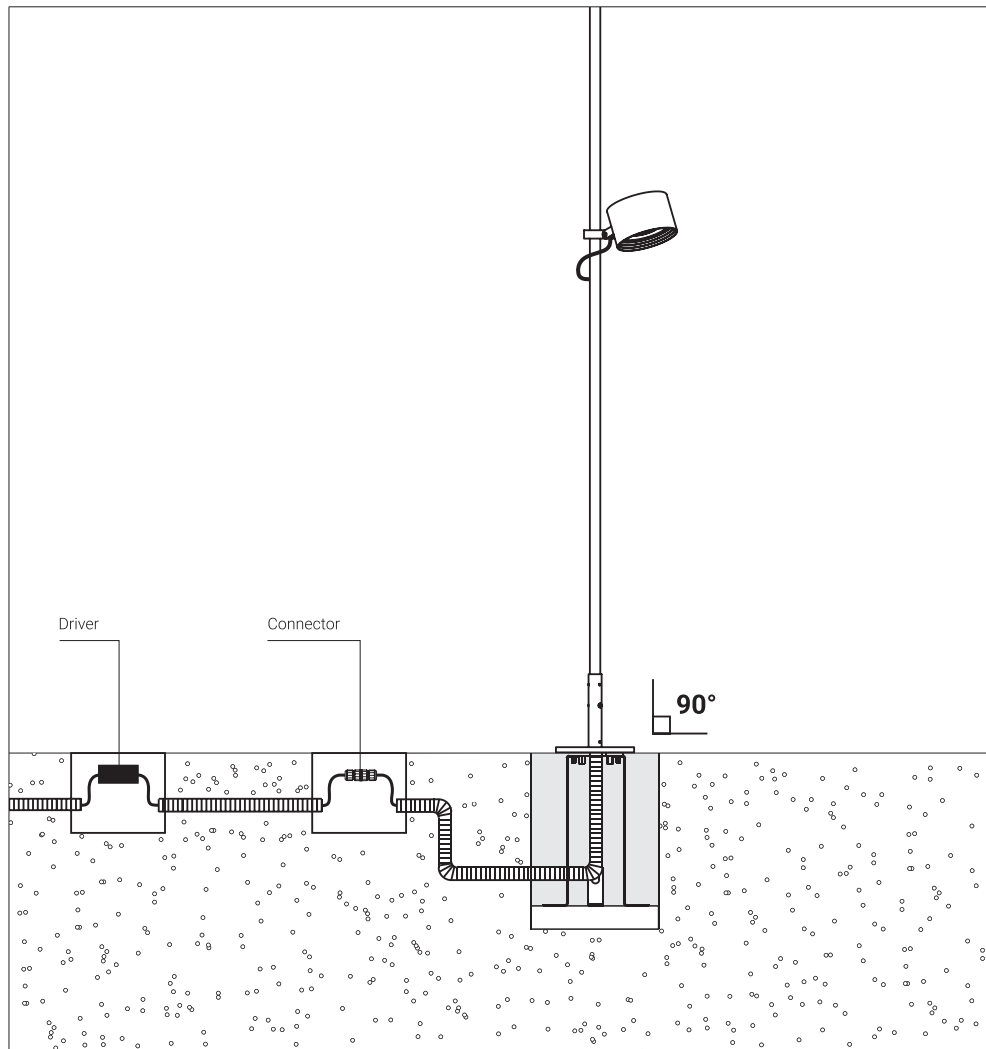
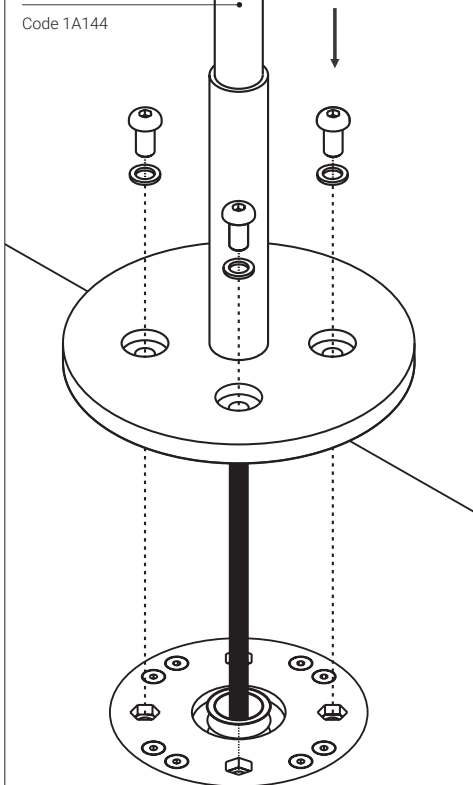

Davide Groppi srl  
Via Belizzi 20 / 22 - 29122 Piacenza - Italia - Ph. +39.0523.571590  
info@davidegroppi.com - www.davidegroppi.com

Davide Groppi srl © 2021  
Società soggetta a direzione e coordinamento di Italian Design Brands spa